

AUTO TRANS DIAGNOSIS - 722 SERIES

Article Text

1996 Mercedes-Benz C220

Copyright © 1998 Mitchell Repair Information Company, LLC
Wednesday, January 26, 2000 12:03PM

ARTICLE BEGINNING

AUTOMATIC TRANSMISSIONS
Mercedes-Benz 722 Series - Electronic Diagnosis

C220, C280, C36, E300D, E320 E420, S320, S350D, S500, S600
SL320, SL500, SL600

APPLICATION & LABOR TIMES

APPLICATION & LABOR TIMES

AA

Year/Vehicle Application	R & I	Labor Times (1)	Overhaul (2)	Transmission Series/Model
-----------------------------	-------	--------------------	--------------	------------------------------

1995				
C220	7.1 12.3 722.423/W4A020
C280	7.1 12.3 722.424/W4A020
C36	7.1 12.3 722.424/W4A020
E300D	6.3 12.3 722.435/W4A020
E320	6.9 12.3 722.369/W4A040
E420	6.9 12.3 722.366/W4A040
S320	6.9 14.8 722.508/W5A030
S350D	6.9 12.3 722.367/W4A040
S500	8.7 12.3 722.370/W4A040
S600	8.7 12.3 722.362/W4A040
SL320	7.2 14.8 722.507/W5A030
SL500	8.7 12.3 722.364/W4A040
SL600	8.7 12.3 722.362/W4A040

1996				
C220	7.1 12.3 722.423/W4A020
C280	7.1 12.3 722.424/W4A020
C36	7.1 12.3 722.424/W4A020
E320	6.3 12.3 722.369/W4A040
E300D	6.3 12.3 722.438/W4A020
S320	6.9 14.8 722.508/W5A030
SL320	7.2 14.8 722.507/W5A030

- (1) - Removal and installation of transmission from vehicle chassis.
- (2) - Bench overhaul time for transmission. DOES NOT include removal and installation.

AA

IDENTIFICATION

Identification code is stamped on identification plate on transmission housing. Use identification code when ordering parts.

DESCRIPTION

AUTO TRANS DIAGNOSIS - 722 SERIES

Article Text (p. 2)

1996 Mercedes-Benz C220

Copyright © 1998 Mitchell Repair Information Company, LLC
Wednesday, January 26, 2000 12:03PM

TRANSMISSION

Transmissions are fully automatic 4 or 5-speed consisting of a 3-element welded torque converter, 2 or 3 compound planetary gear sets, 2 or 3 multiple-disc clutches, one overrunning clutch and 3 brake bands. See Figs. 1 and 2. Brake bands control function of planetary gear sets. A hydraulic system, pressurized by a primary gear type pump and a secondary piston type pump provide working pressure required to operate friction elements and automatic controls.

1st Gear

In 1st gear, brake band B-2 is applied and one-way converter clutch is locked. In selector lever position "2", clutch K-2 is also engaged. Both planetary gear sets are involved in gear reduction.

2nd Gear

In 2nd gear, brake band B-1 and brake band B-2 are applied. Both planetary gear sets are involved in gear reduction.

3rd Gear

In 3rd gear, brake band B-2 is applied and clutch K-1 is engaged. Only rear planetary gear set is involved in gear reduction.

4th Gear

In 4th gear, clutch K-1 and clutch K-2 are applied. Both planetary gear sets rotate as a locked unit.

5th Gear

On 722.5 Series models, clutch K-1, clutch K-2 and overdrive brake are applied in 5th gear. Overdrive clutch and 2nd one-way clutch are also applied in all forward gears.

Reverse Gear

In reverse, brake B-3 is applied, one-way converter clutch is locked, and clutch K-2 is engaged. Both planetary gear sets are involved in gear reduction.

AUTO TRANS DIAGNOSIS - 722 SERIES

Article Text (p. 3)

1996 Mercedes-Benz C220

Copyright © 1998 Mitchell Repair Information Company, LLC
Wednesday, January 26, 2000 12:03PM

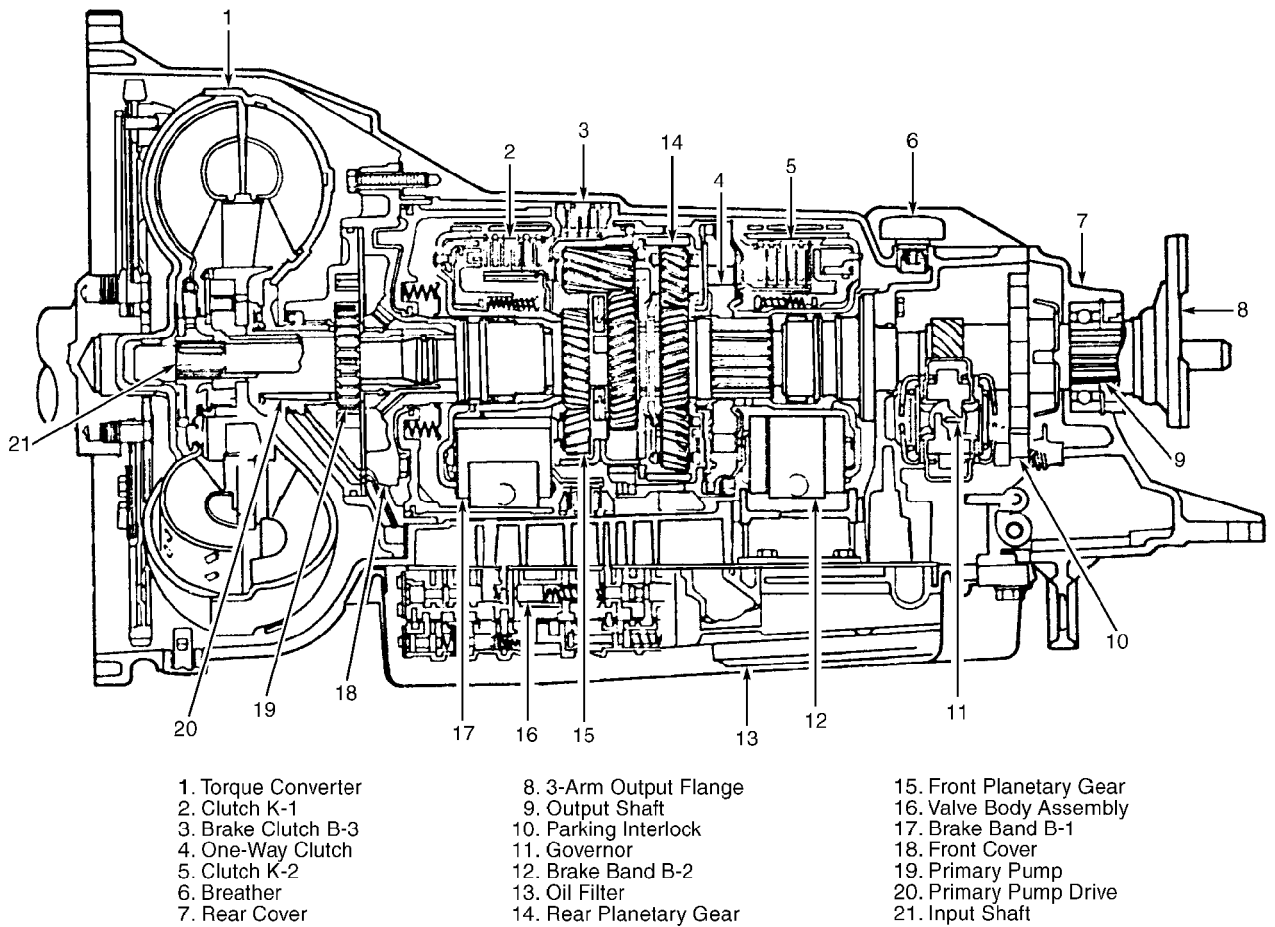

96.130857
Fig. 1: Transmission Component ID (722.3 & 722.4 Series Transmissions)
Courtesy of Mercedes-Benz of North America.

AUTO TRANS DIAGNOSIS - 722 SERIES

Article Text (p. 4)

1996 Mercedes-Benz C220

Copyright © 1998 Mitchell Repair Information Company, LLC
Wednesday, January 26, 2000 12:03PM

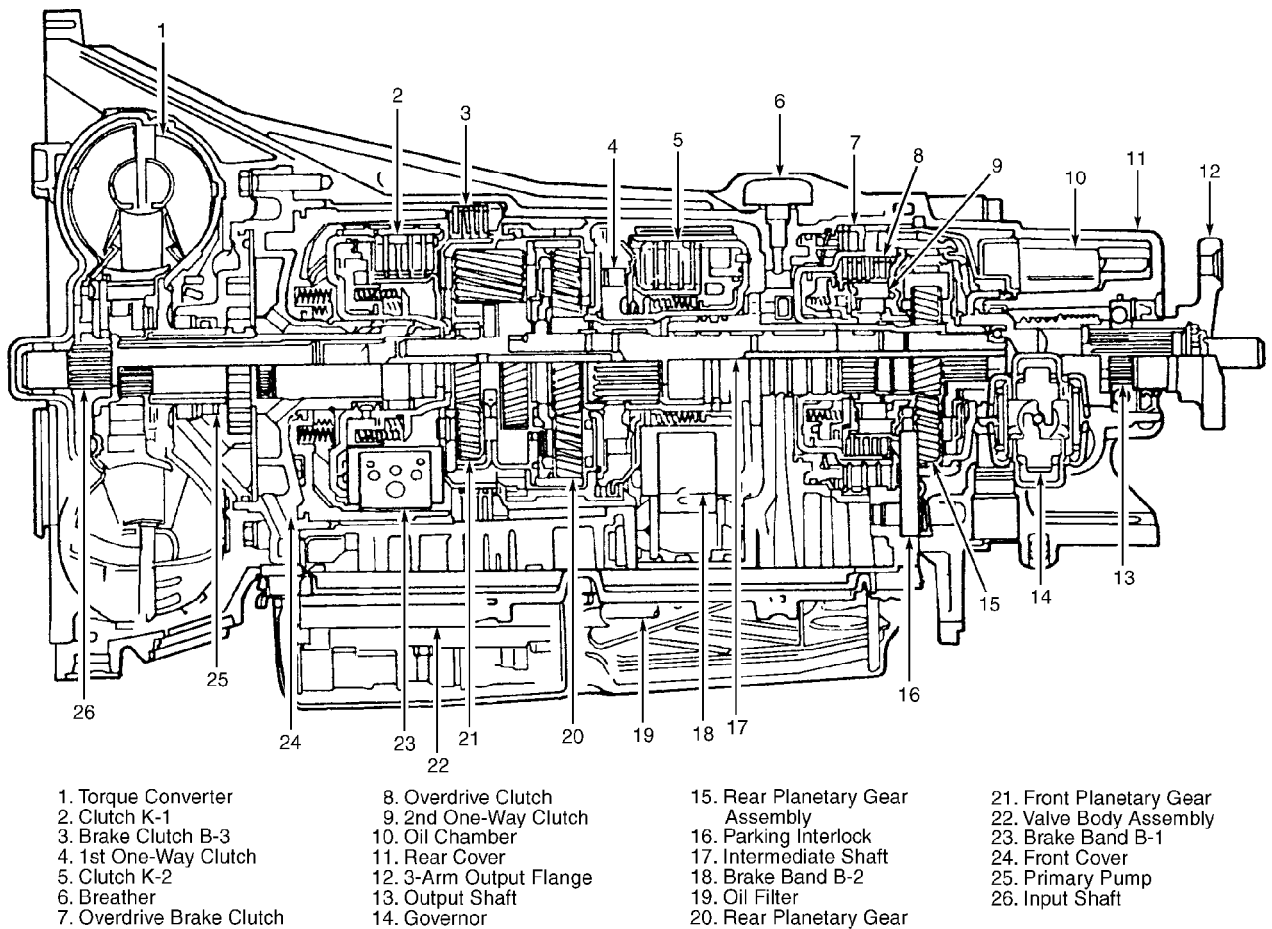

Fig. 2: Transmission Component ID (722.5 Series Transmission)
Courtesy of Mercedes-Benz of North America.

VALVE BODY

Valve body receives inputs from selector lever position, mode selector switch, accelerator pedal position (control pressure), intake manifold vacuum, kickdown function (if activated) and vehicle speed. Depending on operating conditions, oil flow is controlled to various points in transmission and pressure is adapted to requirements.

PRIMARY & SECONDARY PUMP

Primary Pump

Primary pump is housed in front transmission cover and is driven by engine through torque converter. Primary pump operates as long as engine is turning, and supplies pressurized oil to entire hydraulic system. Drive of secondary pump is switched off by cut-off piston, by means of primary pump pressure.

Secondary Pump

Secondary pump is required only for towing and tow-starting vehicle. It is designed as an external gear pump and is positioned in

AUTO TRANS DIAGNOSIS - 722 SERIES

Article Text (p. 5)

1996 Mercedes-Benz C220

Copyright © 1998 Mitchell Repair Information Company, LLC
Wednesday, January 26, 2000 12:03PM

rear section of the transmission. If needed, secondary pump is driven by centrifugal governor shaft. Secondary pump operates only if engine is not running and vehicle is rolling (tow-starting procedure), while brake band B-2 slowly engages. Pump stops operating when vehicle comes to a stop or if transmission has shifted into 4th or 5th gear (engine running).

OPERATING PRESSURES

Working pressure circuit consists of working pressure control valve, basic pressure control valve, 2 two-way check balls, a modulating pressure relief valve, a one-way valve and restrictor. Working pressure circuit is controlled by position of accelerator pedal, vehicle speed, selector lever position, and gear engaged.

Working pressure, governed by working pressure circuit, operates brake B-3, brake bands and clutches. Pressure level is adapted to particular operating condition, regardless of quantity of oil supplied from primary pump or secondary pump. This enables primary pump capacity to be kept as low as possible and the transmission to achieve high efficiency.

Working pressure is always the highest pressure in hydraulic system. All other operating pressures are derived from this pressure and reduced by control valves to a lower pressure level. The following governed pressures control hydraulic system and operate shift element.

- * Reduced Operating Pressure
- * Governor Pressure
- * Lubricating Pressure
- * Modulating Pressure (Vacuum Controlled)
- * Modulating Pressure (Governor Controlled)
- * Full Throttle Pressure
- * Load Dependent Control Pressure
- * Kickdown Control Pressure
- * Boosted Governor Pressure
- * Shift Pressure

DAMPER SYSTEM

Principal task of hydraulic circuits is to control working pressure during gear shifts. During each gear shift transition, engine speed increases (during a downshift) or decreases (during an upshift). In order to provide a smooth transition between gear shifts, 4 independent damper circuits are used.

Clutch K-1 damper circuit controls clutch K-1 during 2nd to 3rd gear downshifts or upshifts. Clutch K-2 damper circuit controls clutch K-2 during 3rd to 4th gear downshifts or upshifts. Brake band B-1 damper circuit controls brake band B-1 during 1st to 2nd gear downshifts or upshifts.

The "engaging" damper circuit controls engagement of clutches or brake bands, depending on selector lever position. When selector lever is moved from "N" position to "D" position or "3" position, brake bands B-1 and B-2 are controlled. When selector lever is moved

AUTO TRANS DIAGNOSIS - 722 SERIES

Article Text (p. 6)

1996 Mercedes-Benz C220

Copyright © 1998 Mitchell Repair Information Company, LLC
Wednesday, January 26, 2000 12:03PM

from "N" position to "2" position, clutch K-2 and brake band B-2 are controlled. When selector lever is moved from "N" position to "R" position, clutch K-2 and disc brake B-3 are controlled. The "engaging" damper controls working pressure pattern after drive positions "R", "D", "3" and "2" are engaged.

TRANSMISSION SHIFT POINT DELAY

The 2nd to 3rd gear upshift on some models is delayed 60-80 seconds to enable catalytic converter to reach its operating temperature quicker. Shift point retard solenoid is energized by CIS-E control unit or air mass sensor control unit through transmission shift point (upshift) retard relay.

Governor pressure is lowered through hydraulic line which is bolted to governor pressure test port. See Fig. 3. Under certain operating conditions (coolant temperature, vehicle speed and time), solenoid valve is de-energized and governor pressure is dumped. The 2-3 upshift is delayed only when coolant temperature is 0-140°F (0-60°C). Operating time is dependent on coolant temperature when engine is started, and is longest when coolant temperature is 68-86°F (20-30°C).

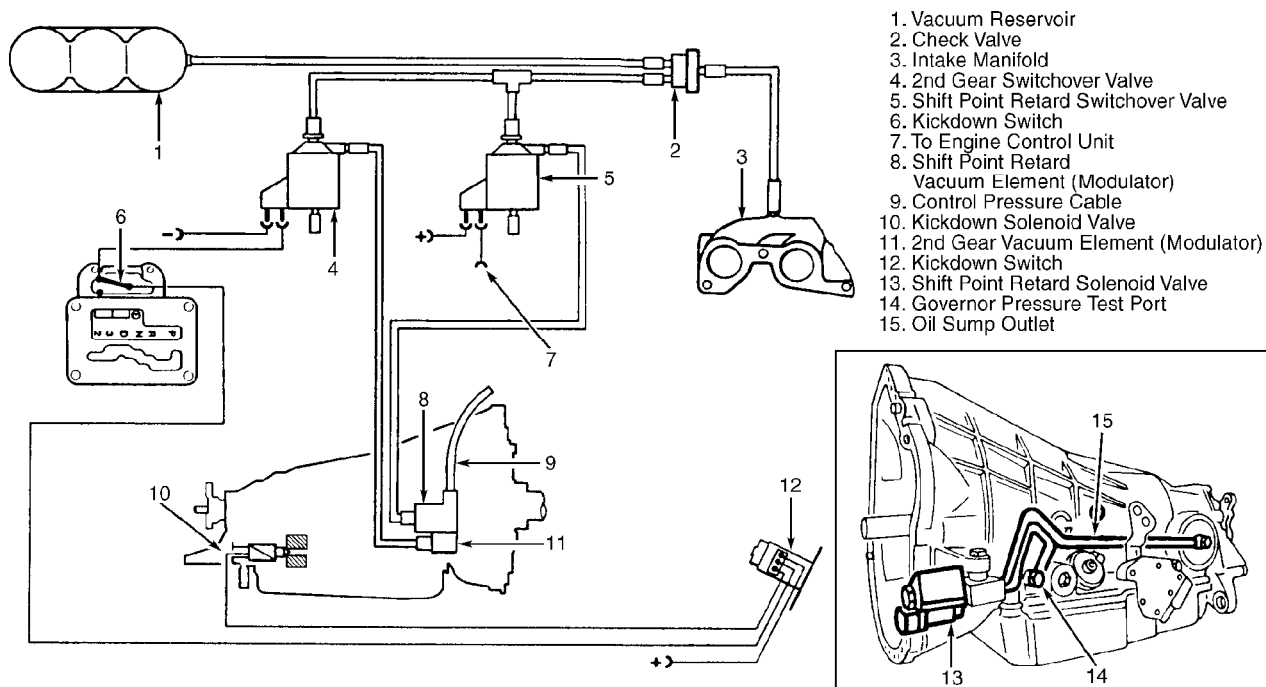

93E24R30

Fig. 3: Identifying Transmission Shift Point Delay Components
Courtesy of Mercedes-Benz of North America.

LUBRICATION & ADJUSTMENTS

NOTE: See appropriate TRANSMISSION SERVICING - A/T article in TRANSMISSION SERVICING section.

AUTO TRANS DIAGNOSIS - 722 SERIES

Article Text (p. 7)

1996 Mercedes-Benz C220

Copyright © 1998 Mitchell Repair Information Company, LLC
Wednesday, January 26, 2000 12:03PM

TROUBLE SHOOTING

TRANSMISSION SLIPS IN ALL GEARS

Incorrect modulating pressure. Modulating pressure control valve or pressure relief valve is dirty or sticking. Vacuum line to transmission vacuum capsule clogged or leaking. Working pressure control valve dirty or sticking. Low working pressure. Defective primary pump.

Transmission Slips When Starting Off In 1st Or 2nd (Reverse Is Okay)

Band B-2 shift valve sticking. Band B-2 piston worn or damaged. Band B-2 adjusted incorrectly or worn or damaged. Adjust brake band B-2 by installing a longer thrust pin (if necessary). If transmission operates properly with selector lever in "2", but not in "3" or "D" position, one-way clutch may be slipping.

Transmission Slips In 2nd Gear Or Shifts From 1st To 3rd Gear

Check control valve B-1 for ease of operation. Replace valve body (if necessary). Remove and install brake band piston B-1, check sealing ring and replace (if necessary). Replace brake band B-1 and thrust body for B-1. Command valve binding.

Transmission Slips During 2-3 Upshift Or Slips Initially, Then Grabs Hold

Check modulating pressure and adjust (if necessary). Check for temperature throttle installation (if equipped). Valve body worn or damaged. Replace valve body (if necessary). Replace inner plates of clutch K-1 or recondition clutch (if necessary). Check front cover Teflon ring.

TRANSMISSION SLIPS DURING 3-4 UPSHIFT

Check and adjust modulating pressure. Governor damaged or working pressure incorrect. Valve body worn or damaged. Replace valve body (if necessary). Check Teflon rings supporting clutch K-2. Replace inner plates of clutch K-2 or recondition clutch (if necessary).

INTERMITTENT NO 5TH GEAR

Check loose connections at throttle valve switch. Check for poor or loose wiring connections between TCM and transmission. See WIRING DIAGRAMS. Ensure proper TCM is installed.

NO 5TH GEAR OR TRANSMISSION SHIFTS TO 5TH UNDER LOAD

Check and repair vacuum line between intake manifold and ignition control unit.

NO POSITIVE ENGAGEMENT IN REVERSE

AUTO TRANS DIAGNOSIS - 722 SERIES

Article Text (p. 8)

1996 Mercedes-Benz C220

Copyright © 1998 Mitchell Repair Information Company, LLC
Wednesday, January 26, 2000 12:03PM

Check plates and sealing rings on brake B-3 piston. Replace if necessary.

HARSH ENGAGEMENT WHEN SHIFTING GEARS

Incorrect working pressure. Check and adjust modulating pressure. Check vacuum line and connections for leaks. On vehicles equipped with diesel engines, check vacuum control valve. Coolant entering transmission oil cooler and contaminating transmission fluid. Replace radiator. If necessary, replace all friction linings and/or replace transmission.

HARSH ENGAGEMENT WHEN SELECTING "D" OR "R"

Idle speed too high. Check pressure receiving (pick-up) piston in valve body for ease of operation and correct installation. Replace valve body (if necessary).

NOTE: Pressure pick-up requires a running period of approximately 2 seconds. Harsh engagement may occur during repeated shifts between "N" and "D". If harshness takes place within 2 seconds, condition is considered normal.

HARSHNESS ON 4-3 DOWNSHIFT

Sealing ring on release end of band B-2 worn or damaged. Band B-2 piston worn or damaged. Band B-2 thrust body damaged.

CHATTER DURING UPSHIFT

Valve body malfunction. Check and repair or replace valve body.

WILL NOT UPSHIFT

Incorrect governor pressure. Defective governor assembly. Check for stuck kickdown solenoid or for constant voltage to solenoid caused by a defective fuel pump relay or sticking kickdown switch. Valve body dirty or valves sticking. Repair or replace valve body.

UPSHIFTS AT HIGHER SPEEDS THAN SPECIFIED

Check pressure control cable engagement, condition and adjustment. Check for stuck kickdown solenoid or for constant voltage to solenoid caused by a defective fuel pump relay or sticking kickdown switch. Check governor pressure. If regulator pressure is too low, replace centrifugal governor. Ensure control pressure regulating valve is operable.

UPSHIFTS AT LOWER SPEEDS THAN SPECIFIED

Check pressure control cable engagement, condition and

AUTO TRANS DIAGNOSIS - 722 SERIES

Article Text (p. 9)

1996 Mercedes-Benz C220

Copyright © 1998 Mitchell Repair Information Company, LLC
Wednesday, January 26, 2000 12:03PM

adjustment. Check full throttle stop by accelerating engine and ensuring throttle valve rests against full throttle stop. Readjust throttle stop (if necessary). Check governor pressure. If governor pressure is too high, replace centrifugal governor. Repair or replace valve body.

NO KICKDOWN

Check throttle control and pressure control cable engagement, condition and adjustment. Connect kickdown solenoid to battery and check for proper operation. Replace solenoid (if necessary). Check kickdown valve in valve body. Replace valve body (if necessary).

NO 4-3 OR 3-2 DOWNSHIFT

Control pressure cable out of adjustment. Leaking vacuum hoses and/or connections. Ensure brake shaft piston is operable. Replace valve body (if necessary).

UNCONTROLLED DOWNSHIFTS OUTSIDE RANGE OF KICKDOWN SWITCH

Remove kickdown solenoid. Check "O" ring on kickdown solenoid for damage. Check kickdown switch for sticking in pushed-in position. Replace switch (if necessary). Check for kickdown solenoid stuck in opened position. Replace kickdown solenoid (if necessary).

POOR ACCELERATION FROM STOPPED POSITION

Check stall speed. If stall speed is 400-700 RPM less than specified value, one-way clutch in torque converter is slipping. Replace torque converter (if necessary).

PARKING PAWL WILL NOT ENGAGE

Check rear engine mount. Replace engine mount (if necessary). Check adjustment of selector rod. Adjust selector rod (if necessary).

SELECTOR LEVER DOES NOT ENGAGE IN "R" OR "P"

With engine running, clean centrifugal governor and ensure correct operation. With engine not running, check operation of detent piston in lower cover.

ENGINE WILL NOT START IN "P" OR "N" POSITION

Adjust shift rod and starter lock-out switch. Replace starter lock-out switch (if necessary).

SMOKE IN EXHAUST (FLUID LOSS)

Diaphragm in vacuum control unit defective. Transmission oil is being drawn from engine through vacuum line. Replace vacuum control

AUTO TRANS DIAGNOSIS - 722 SERIES

Article Text (p. 10)

1996 Mercedes-Benz C220

Copyright © 1998 Mitchell Repair Information Company, LLC
Wednesday, January 26, 2000 12:03PM

unit (if necessary).

FLUID LOSS BETWEEN TORQUE CONVERTER & PRIMARY PUMP

Seal torque converter oil drain plug. If leak continues, replace radial sealing ring and "O" ring on primary pump. Check primary pump "O" ring groove for porosity. Replace primary pump (if necessary).

HOWLING NOISE WHEN CHANGING GEARS (UNDER FULL LOAD)

Replace transmission oil filter.

HOWLING NOISE WHICH INCREASES AS ENGINE RPM INCREASES

Check primary pump and replace if necessary.

1ST GEAR & REVERSE TOO LOUD

Replace front planetary gear set. Reverse and 1st gear are louder than forward (driving) gears due to gear reduction. If noise seems too loud, or if in doubt, a similar vehicle should be used for comparison.

3RD GEAR TOO LOUD

Replace rear planetary gear set.

RATTLING NOISE AT 1500 RPM IN ALL POSITIONS EXCEPT "R"

Brake B-3 plates are vibrating in transmission housing. Replace brake B-3 plates, install damper spring and set release clearance to minimum value.

LIGHT GRINDING NOISE IN "P" & "N" POSITIONS

This condition is normal if a "rolling" noise of front planetary gear set is heard. If noise seems too loud, or if in doubt, a similar vehicle should be used for comparison.

"ROLLING" NOISES WHEN DRIVING IN REVERSE

Disc brake B-3 release clearance too great. Adjust release clearance to .06-.08" (1.5-2.0 mm) or replace disc brake plates. Outside plate carrier of clutch K-1 contacts piston.

Primary Pump Bushing Loosens After A Short Operating Period - Dowel pins for centering transmission to engine are not in place.

TESTING

VACUUM CONTROL CIRCUIT

AUTO TRANS DIAGNOSIS - 722 SERIES

Article Text (p. 11)

1996 Mercedes-Benz C220

Copyright © 1998 Mitchell Repair Information Company, LLC
Wednesday, January 26, 2000 12:03PM

Vacuum Control Valve (E300D & S350D)

1) Ensure engine is at normal operating temperature and throttle linkage is adjusted properly. Disconnect Black/White vacuum hose and connect vacuum/pressure tester.

2) Start engine and check vacuum at idle. Vacuum should be 11.6-13.2 in. Hg (395-445 mbar) with Red or Blue colored cap; 10.6-12.1 in. Hg (360-410 mbar) with Black colored cap. Stop engine and place throttle linkage at full throttle stop. Vacuum reading should be zero.

3) If vacuum readings are correct, vacuum control valve is okay. If readings are not correct, check vacuum hose routing. See Fig. 4. If routing is correct, check vacuum pump. If pump is okay, adjust vacuum control valve and replace (if necessary).

Vacuum Amplifier (E300D & S350D)

1) Disconnect vacuum hose and damper at vacuum control valve. Plug vacuum control valve opening. Disconnect pressure hose running from aneroid compensator (ALDA) to vacuum amplifier, and connect tester to overpressure side of detached hose.

2) If vehicle has only one hose at aneroid compensator, connect test hose directly to vacuum amplifier PRE (boost pressure) connection. Simulate boost pressure of 21.9 in. Hg (740 mbar). Replace vacuum transducer if leak is present.

3) Using a "T" fitting, connect tester at vacuum end of vacuum transducer connection TRA (transmission). Start engine and check vacuum at idle. Vacuum should be .59-1.8 in. Hg (20-60 mbar). If vacuum readings are correct, vacuum amplifier is okay. If readings are not correct, check vacuum hose routing. If routing is correct, replace vacuum amplifier.

AUTO TRANS DIAGNOSIS - 722 SERIES

Article Text (p. 12)

1996 Mercedes-Benz C220

Copyright © 1998 Mitchell Repair Information Company, LLC
Wednesday, January 26, 2000 12:03PM

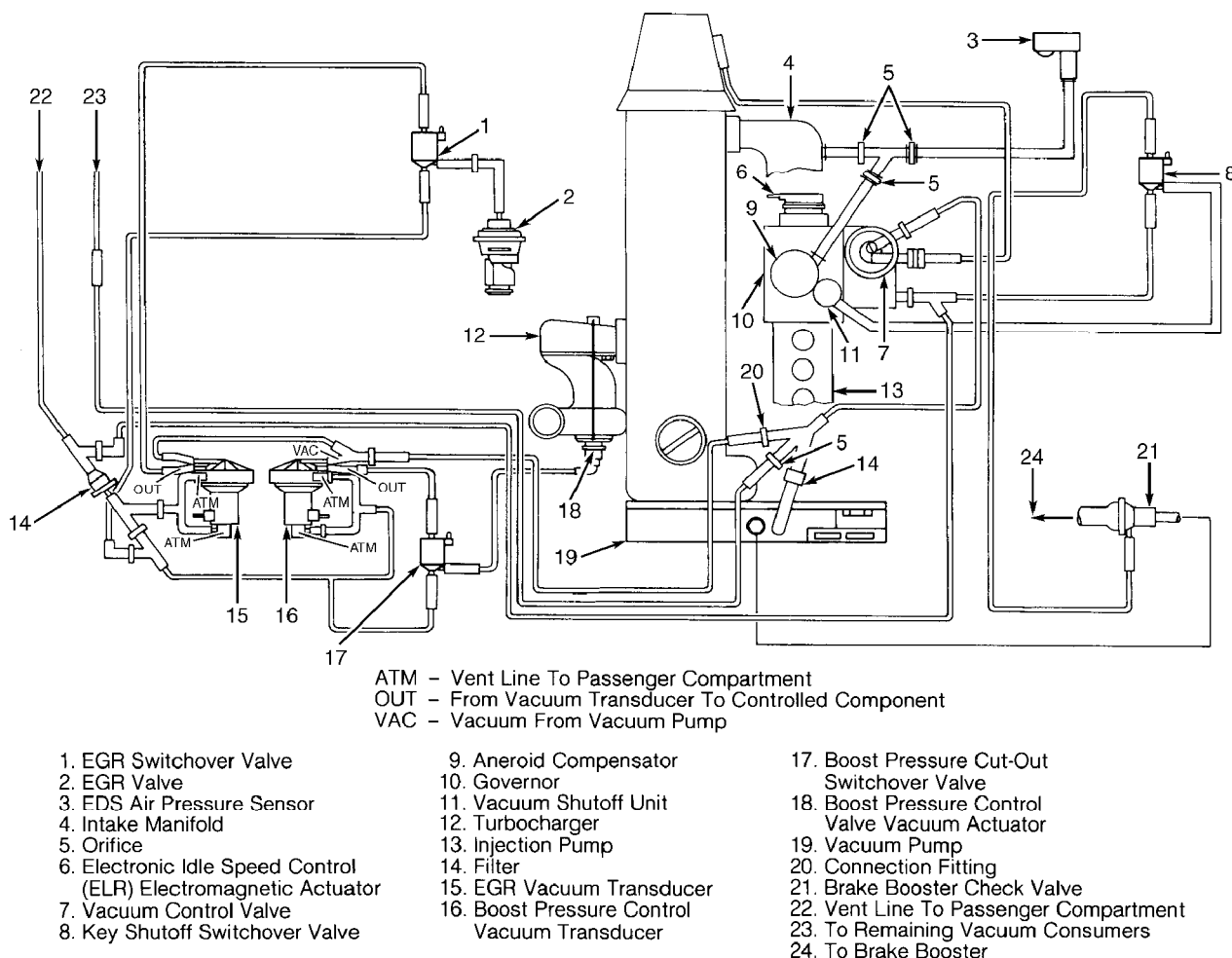

93G79554
Fig. 4: Vacuum Control Circuit Diagram (S350D Shown; E300D Is Similar)
Courtesy of Mercedes-Benz of North America.

ROAD TEST

NOTE: Before road testing, check transmission fluid level, idle speed and control pressure cable adjustment. See appropriate TRANSMISSION SERVICING - A/T article in TRANSMISSION SERVICING section.

1) During road test, transmission should upshift and downshift at approximate speeds shown in appropriate SHIFT SPEEDS table. All shifts may vary somewhat due to production tolerances or tire size. The important factor is quality of shifts. All shifts should be smooth, responsive and with no engine speed flare-up.

NOTE: If transmission shift point delay feature is used (see Fig. 3), the 2-3 upshift under light throttle (partially depressed accelerator pedal) will be higher with engine cold.

2) Slipping or engine RPM flare-up usually indicates clutch

AUTO TRANS DIAGNOSIS - 722 SERIES

Article Text (p. 13)

1996 Mercedes-Benz C220

Copyright © 1998 Mitchell Repair Information Company, LLC
Wednesday, January 26, 2000 12:03PM

or band problems. Slipping clutch or band in particular gear can usually be identified by noting transmission operation in all gear positions and comparing which internal units are applied in those positions. See CLUTCH & BAND APPLICATION CHART.

3) This process of elimination can be used to detect any unit which slips and to test proper operation of good units. Cause of malfunction usually cannot be decided. Most conditions may be caused by leaking hydraulic circuits or sticking valves. Unless an obvious condition exists, transmission should never be disassembled until hydraulic pressure tests have been performed.

CLUTCH & BAND APPLICATION CHART

AA

Selector Lever Position	Elements In Use (1)
"D"	
1st Gear	B-2 Brake & One-Way Clutch
2nd Gear	B-1 Brake & B-2 Brake
3rd Gear	B-2 Brake & K-1 Clutch
4th Gear	K-1 Clutch & K-2 Clutch
5th Gear	K-1 Clutch, K-2 Clutch & Overdrive Brake
"3"	
1st Gear	B-2 Brake & One-Way Clutch
2nd Gear	B-1 Brake & B-2 Brake
3rd Gear	B-2 Brake & K-1 Clutch
"2"	
1st Gear	B-2 Brake, (2) K-2 Clutch & One-Way Clutch,
2nd Gear	B-1 Brake & B-2 Brake
"R"	B-3 Brake, (2) K-2 Clutch & One-Way Clutch
"N" & "P"	All Clutches & Bands Released

- (1) - Overdrive clutch and 2nd one-way clutch are also in effect on 722.5 series transmissions.
- (2) - Applied but not effective. K-2 clutch provides engine braking in Reverse and manual low.

AA

C220 SHIFT SPEEDS - SHIFT LEVER IN "D"

AA

Application	MPH
Full Throttle	
1-2 Upshift	27
2-3 Upshift	48
3-4 Upshift	80
4-3 Downshift	67
3-2 Downshift	29
2-1 Downshift	10
Kickdown	
1-2 Upshift	30
2-3 Upshift	53
3-4 Upshift	83

AUTO TRANS DIAGNOSIS - 722 SERIES

Article Text (p. 14)

1996 Mercedes-Benz C220

Copyright © 1998 Mitchell Repair Information Company, LLC
Wednesday, January 26, 2000 12:03PM

4-3 Downshift	75
3-2 Downshift	45
2-1 Downshift	17

AA

C280 SHIFT SPEEDS - SHIFT LEVER IN "D"

AA

Application	MPH
Full Throttle	
1-2 Upshift	29
2-3 Upshift	58
3-4 Upshift	99
4-3 Downshift	70
3-2 Downshift	28
2-1 Downshift	11
Kickdown	
1-2 Upshift	37
2-3 Upshift	64
3-4 Upshift	103
4-3 Downshift	92
3-2 Downshift	54
2-1 Downshift	23

AA

E300D SHIFT SPEEDS - SHIFT LEVER IN "D"

AA

Application	MPH
Full Throttle	
1-2 Upshift	26
2-3 Upshift	48
3-4 Upshift	81
4-3 Downshift	50
3-2 Downshift	26
2-1 Downshift	15
Kickdown	
1-2 Upshift	29
2-3 Upshift	51
3-4 Upshift	82
4-3 Downshift	72
3-2 Downshift	41
2-1 Downshift	23

AA

E320 SHIFT SPEEDS - SHIFT LEVER IN "D"

AA

Application	MPH
Full Throttle	
1-2 Upshift	36
2-3 Upshift	68

AUTO TRANS DIAGNOSIS - 722 SERIES

Article Text (p. 16)

1996 Mercedes-Benz C220

Copyright © 1998 Mitchell Repair Information Company, LLC
Wednesday, January 26, 2000 12:03PM

S350 SHIFT SPEEDS - SHIFT LEVER IN "D"

AA

Application MPH

Full Throttle

1-2 Upshift	23
2-3 Upshift	47
3-4 Upshift	75
4-3 Downshift	53
3-2 Downshift	29
2-1 Downshift	13

Kickdown

1-2 Upshift	30
2-3 Upshift	52
3-4 Upshift	80
4-3 Downshift	72
3-2 Downshift	45
2-1 Downshift	19

AA

S420 SHIFT SPEEDS - SHIFT LEVER IN "D"

AA

Application MPH

Full Throttle

1-2 Upshift	30
2-3 Upshift	67
3-4 Upshift	107
4-3 Downshift	75
3-2 Downshift	26
2-1 Downshift	15

Kickdown

1-2 Upshift	44
2-3 Upshift	73
3-4 Upshift	111
4-3 Downshift	100
3-2 Downshift	60
2-1 Downshift	25

AA

S500 & SL500 SHIFT SPEEDS - SHIFT LEVER IN "D"

AA

Application MPH

Full Throttle

1-2 Upshift	32
2-3 Upshift	72
3-4 Upshift	113
4-3 Downshift	80
3-2 Downshift	27
2-1 Downshift	17

Kickdown

AUTO TRANS DIAGNOSIS - 722 SERIES

Article Text (p. 17)

1996 Mercedes-Benz C220

Copyright © 1998 Mitchell Repair Information Company, LLC
Wednesday, January 26, 2000 12:03PM

1-2 Upshift	46
2-3 Upshift	78
3-4 Upshift	117
4-3 Downshift	106
3-2 Downshift	63
2-1 Downshift	27

AA

SL320 SHIFT SPEEDS - SHIFT LEVER IN "D"

AA

Application (1)	MPH
Full Throttle	
1-2 Upshift	27
2-3 Upshift	51
3-4 Upshift	81
4-5 Upshift	123
Kickdown	
1-2 Upshift	32
2-3 Upshift	55
3-4 Upshift	86
4-5 Upshift	123

(1) - Downshift speed specification for 722.5 series are not available.

AA

HYDRAULIC PRESSURE TEST

NOTE: Working pressure specification for 722.5 series transmission is not available.

Preliminary Test

1) Before performing tests, check fluid level and condition, throttle linkage, EGR system and neutral safety switch. Correct as necessary. Connect pressure gauge to appropriate pressure port on transmission. See Fig. 5.

2) Attach pressure gauge to inside mirror in such a manner that it can be easily read from driver's seat. Run pressure hoses through passenger window.

3) Ensure pressure hoses do not drag on pavement or contact exhaust system. After test, run engine and check pressure ports for leaks.

Modulating Pressure Test

1) Remove vacuum line and holder from vacuum control unit (modulator). Place transmission in "D" position and drive vehicle on road or on dynamometer at 31 MPH. Apply full throttle and maintain speed at 31 MPH by lightly applying brakes.

2) Read resulting pressure on gauge attached to modulating pressure port on transmission. Pressure should be as shown in MODULATING PRESSURE table.

AUTO TRANS DIAGNOSIS - 722 SERIES

Article Text (p. 18)

1996 Mercedes-Benz C220

Copyright © 1998 Mitchell Repair Information Company, LLC
 Wednesday, January 26, 2000 12:03PM

3) If necessary, adjust modulating pressure. Modulator pressure port is next to vacuum control unit at 4 o'clock position. Disconnect vacuum hose and remove rubber cap from vacuum control unit. Pull "T" handle out of locking slots to permit rotation. Turning "T" handle one rotation in vacuum control unit results in pressure change of about 6 psi (.422 kg/cm²). Adjust to correct value. See MODULATING PRESSURE table.

4) After adjusting pressure, push "T" handle back into locking slots. Put rubber cap back on vacuum control unit. Connect vacuum hose, and check modulating pressure.

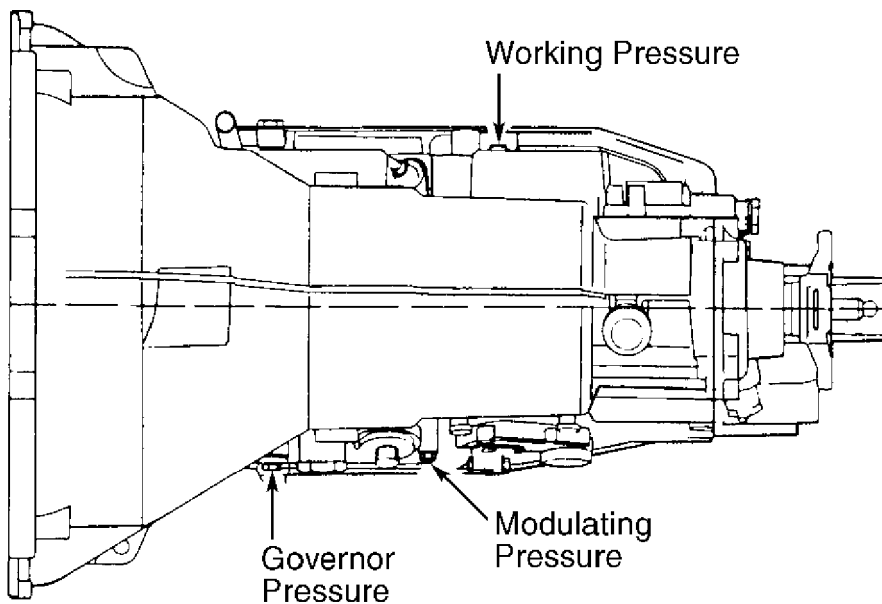

93H24833

Fig. 5: Locating Pressure Test Ports
 Courtesy of Mercedes-Benz of North America.

MODULATING PRESSURE

AA

Model	(1) psi (kPa)
C220	53.7 (370)
C280	56.6 (390)
E300D	47.1 (325)
E320	60.9 (420)
S350D	44.9 (310)
E420	55.1 (380)
S320	58.0 (400)
S420	55.1 (380)
S500	58.0 (400)
SL320	58.0 (400)

(1) - Measure pressure in "D" position at 31 MPH.

AA

NOTE: Modulating pressure must be measured and adjusted before

AUTO TRANS DIAGNOSIS - 722 SERIES

Article Text (p. 19)

1996 Mercedes-Benz C220

Copyright © 1998 Mitchell Repair Information Company, LLC
Wednesday, January 26, 2000 12:03PM

performing working pressure and governor pressure tests.

Working Pressure Test

1) Disconnect vacuum line from vacuum control unit (modulator). Start and run engine at 1000 RPM while reading pressure. Pressure should be as shown in WORKING PRESSURE table.

2) Working pressure is not adjustable. Measurement simply provides information concerning operation of working pressure regulator valve in valve housing.

WORKING PRESSURE

XX

Model	(1) psi (kPa)
C220, C280 & C36	(2)
E300D	212-239 (1460-1660)
E320	174-203 (1200-1400)
S350D	213-242 (1470-1670)
E420 & S420	160-174 (1100-1200)
S320 & SL320	(2)
S500 & SL500	186-215 (1280-1480)

(1) - Measure pressure in "D" position with vehicle stationary.
(2) - Information not available.

XX

Governor Pressure

Drive vehicle on road or on dynamometer at speeds indicated in GOVERNOR PRESSURE table. Compare pressures noted on gauge with pressures given in table.

NOTE: Governor pressure is a part of working pressure and is controlled by governor assembly on output shaft. If values are not within specifications, disassemble and clean governor assembly.

GOVERNOR PRESSURE

XX

Model	psi (kPa) @ 19 MPH	psi (kPa) @ 56 MPH
C220, C280 & C36	(1)	(1)
E300D & S350D	11.6 (80)	37.7 (260)
E320	11.6 (80)	37.7 (260)
E420 & S420	10.2 (70)	30.5 (210)
S320 & SL320	(1)	(1)
S500 & SL500	8.7 (60)	29.0 (200)

(1) - Information not available.

XX

STALL TEST

AUTO TRANS DIAGNOSIS - 722 SERIES

Article Text (p. 20)

1996 Mercedes-Benz C220

Copyright © 1998 Mitchell Repair Information Company, LLC
Wednesday, January 26, 2000 12:03PM

Information not available.

ON-VEHICLE SERVICE

The following components may be removed from transmission without removing transmission from vehicle: oil pan and gasket, valve body, vacuum control unit, speedometer driven gear assembly, secondary pump assembly, extension housing, pressure receiving piston, modulating pressure housing and bimetallic spring, speedometer drive gear, secondary pump eccentric, governor assembly, parking pawl and parking linkage. For removal and installation procedures for these components, see TRANSMISSION DISASSEMBLY and TRANSMISSION REASSEMBLY.

REMOVAL & INSTALLATION

See appropriate TRANSMISSION REMOVAL & INSTALLATION - A/T article in TRANSMISSION SERVICING section.

TORQUE CONVERTER

NOTE: Torque converter is a sealed unit and cannot be disassembled for service. If hub of converter is scored or if metallic particles are found in transmission fluid, replace torque converter.

TRANSMISSION DISASSEMBLY

722.3 & 722.4 SERIES

1) Remove control pressure cable sleeve by pressing tab inward, turning cable counterclockwise 90 degrees, and pulling sleeve upward. Detach selector lever cable by releasing locking device with a screwdriver. Position transmission in holding fixture and mounting plate with oil pan facing upward.

2) Remove oil pan and gasket. Remove oil filter and valve body, noting length and location of valve body bolts. Remove leaf spring and bracket. See Fig. 6. Remove lower cover, intermediate plate and oil pipe assembly.

3) Remove one-way check valve, brake band B-3 guide, locating pin, oil deflector, temperature (throttle) restrictor, and filler piece (if equipped). Remove snap ring and brake band B-2 piston cover. Remove brake band B-2 piston and thrust pin.

4) Attach assembly fixture to transmission housing. Compress brake band B-1 piston cover and remove snap ring. Loosen assembly fixture and remove brake band B-1 piston cover. Remove brake band B-1 piston, thrust pin and return springs. Remove brake band B-1 guide.

AUTO TRANS DIAGNOSIS - 722 SERIES

Article Text (p. 21)

1996 Mercedes-Benz C220

Copyright © 1998 Mitchell Repair Information Company, LLC
 Wednesday, January 26, 2000 12:03PM

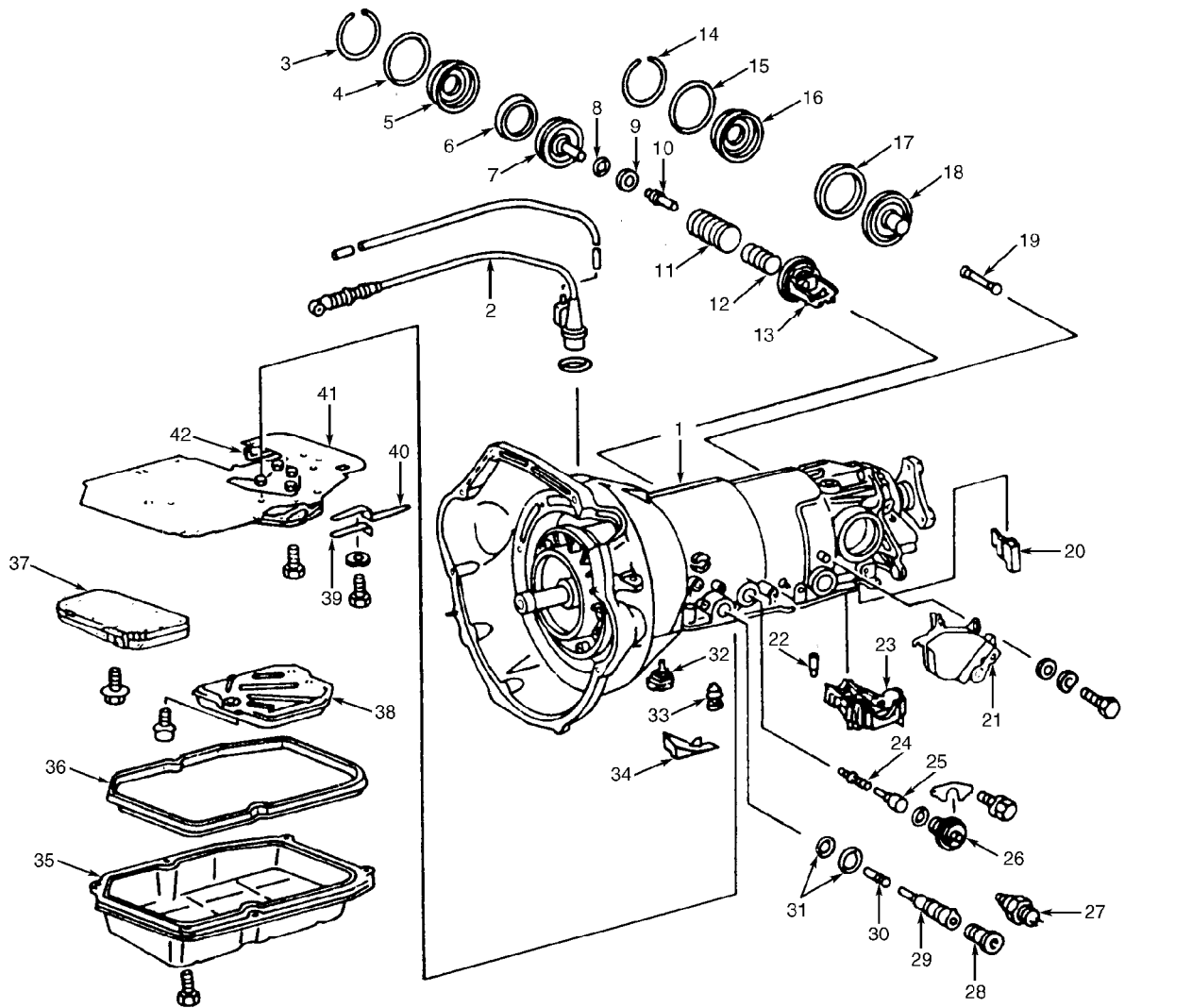

- | | | | |
|--------------------------------|---------------------------------|---|--------------------------|
| 1. Transmission | 12. Return Spring | 23. Brake Band B-3 Guide | 32. Temperature Throttle |
| 2. Control Pressure Cable | 13. Brake Band B-1 Guide | 24. Modulating Pressure Control Valve | 33. One-Way Check Valve |
| 3. Snap Ring | 14. Snap Ring | 25. Heat Expansion Pin | 34. Oil Deflector |
| 4. "O" Ring | 15. "O" Ring | 26. Vacuum Control Unit (Modulator) | 35. Oil Pan |
| 5. Brake Band B-1 Piston Cover | 16. Brake Band B-2 Piston Cover | 27. Transmission Overload Protection Switch (If Equipped) | 36. Gasket |
| 6. Lip Sealing Ring | 17. Lip Sealing Ring | 28. Screw-On Plug (If Equipped) | 37. Valve Body |
| 7. Brake Band B-1 Piston | 18. Brake Band B-2 Piston | 29. Brake Band B-1 Thrust Element Of Thrust Bearing | 38. Oil Filter |
| 8. Shim(s) | 19. Thrust Pin | 30. Thrust Pin | 39. Bracket |
| 9. Shim(s) | 20. Filler Piece (If Equipped) | 31. "O" Rings | 40. Leaf Spring |
| 10. Thrust Pin | 21. Starter Lock-Out Switch | | 41. Intermediate Plate |
| 11. Return Spring | 22. Locating Pin | | 42. Oil Pipe |

93124834

Fig. 6: Exploded View Of Transmission Case External Components (722.3 & 722.4 Series)

Courtesy of Mercedes-Benz of North America.

5) Remove transmission overload protection switch or screw-on plug for brake band B-1 thrust element and thrust pin. Remove gear selector lever and starter lock-out switch. Remove vacuum control unit (modulator) and retaining plate. Remove modulating pressure control valve and heat expansion pin.

6) Remove kickdown solenoid. Remove output shaft nut. Remove

AUTO TRANS DIAGNOSIS - 722 SERIES

Article Text (p. 22)

1996 Mercedes-Benz C220

Copyright © 1998 Mitchell Repair Information Company, LLC
Wednesday, January 26, 2000 12:03PM

3-arm output flange and washer. See Fig. 7. Remove shift point retard switchover valve and oil sump drain tube (if equipped). Remove transmission rear cover.

7) Remove mechanical speedometer drive oil pipe (if equipped). Remove parking lock gear, parking lock pawl, spring and shim(s) from output shaft. Pull out plastic guide, roller, bolt and oil pipe (if equipped).

8) Remove shaft (or bolt), linkage and detent plate assembly. Remove snap ring and governor cover. Remove nut for axial retainer (if equipped). See Fig. 42. Pivot axial retainer rearward and remove governor assembly. Remove axial retainer, helical gear and snap ring. Remove secondary pump, "O" ring and intermediate plate.

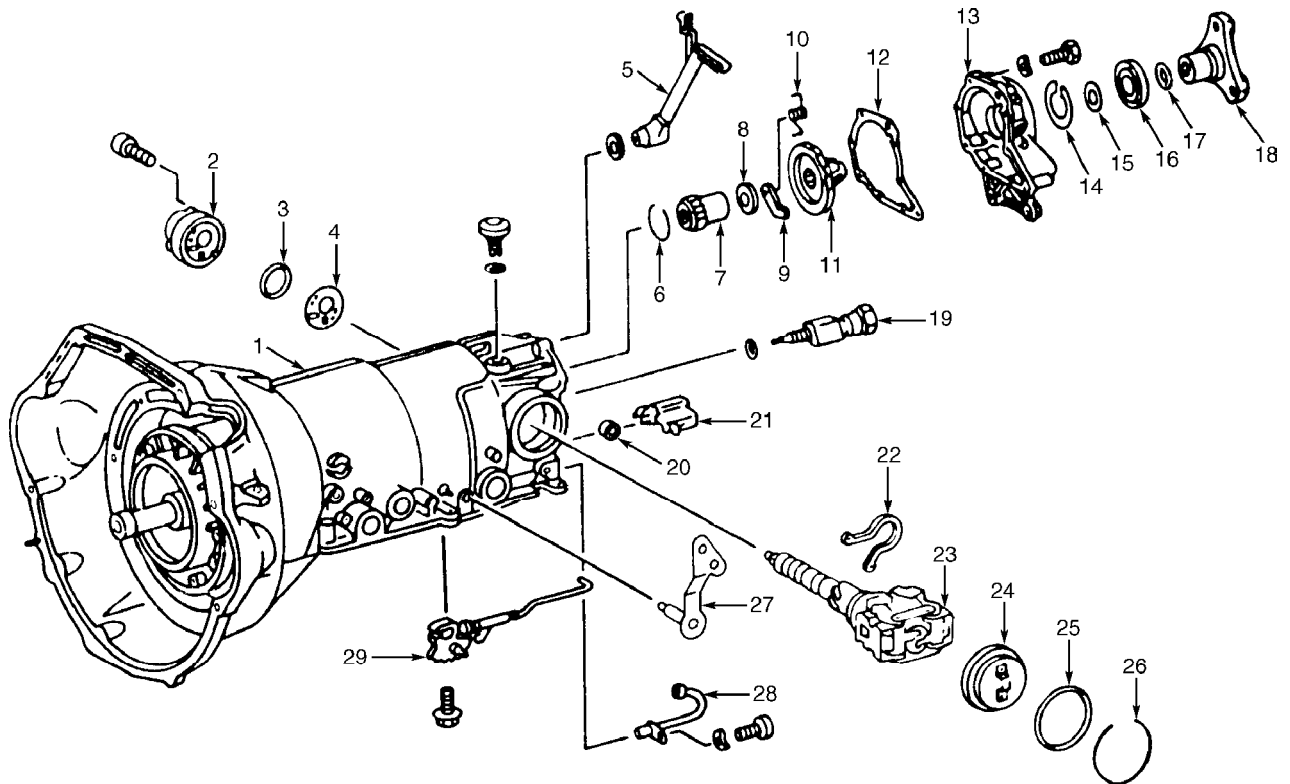

1. Transmission
2. Secondary Pump
3. "O" Ring
4. Intermediate Plate
5. Oil Pipe (Mechanical Speedometer Only)
6. Snap Ring
7. Helical Gear (Mechanical Speedometer Only)
8. Shim
9. Parking Lock Pawl
10. Spring

11. Parking Lock Gear
12. Gasket
13. Transmission Rear Cover
14. Snap Ring
15. Washer
16. Seal
17. Shim
18. 3-Arm Output Flange
19. Kickdown Solenoid
20. Plastic Guide

21. Roller
22. Axial Retainer
23. Governor Assembly
24. Cover
25. "O" Ring
26. Snap Ring
27. Range (Gear) Selector Lever
28. Oil Pipe
29. Detent Assembly

93J24835

Fig. 7: Exploded View Of Transmission Rear Cover, Governor & Secondary Pump Assemblies (722.3 & 722.4 Series)

Courtesy of Mercedes-Benz of North America.

9) Install 2 long bolts into threaded holes in front cover. Tighten bolts to pull out cover. Remove bolts and front cover

AUTO TRANS DIAGNOSIS - 722 SERIES

Article Text (p. 23)

1996 Mercedes-Benz C220

Copyright © 1998 Mitchell Repair Information Company, LLC
Wednesday, January 26, 2000 12:03PM

assembly, noting location of Teflon rings. See Fig. 8. Hold planetary gear set on input shaft and carefully remove assembly. Remove brake band B-1 and clutch K-1. Remove compensating (spring) washer and brake B-3 inner and outer plates.

10) Remove brake band B-2 damping spring, thrust pin, and clutch K-2. See Fig. 8. Remove thrust washer from support flange. Remove support flange, "O" ring and Teflon rings.

11) Compress brake band B-2 as much as possible and remove snap ring. Remove brake band piston. Remove brake band B-2 thrust element. Remove "O" rings, sealing rings, and aluminum sealing rings from transmission housing.

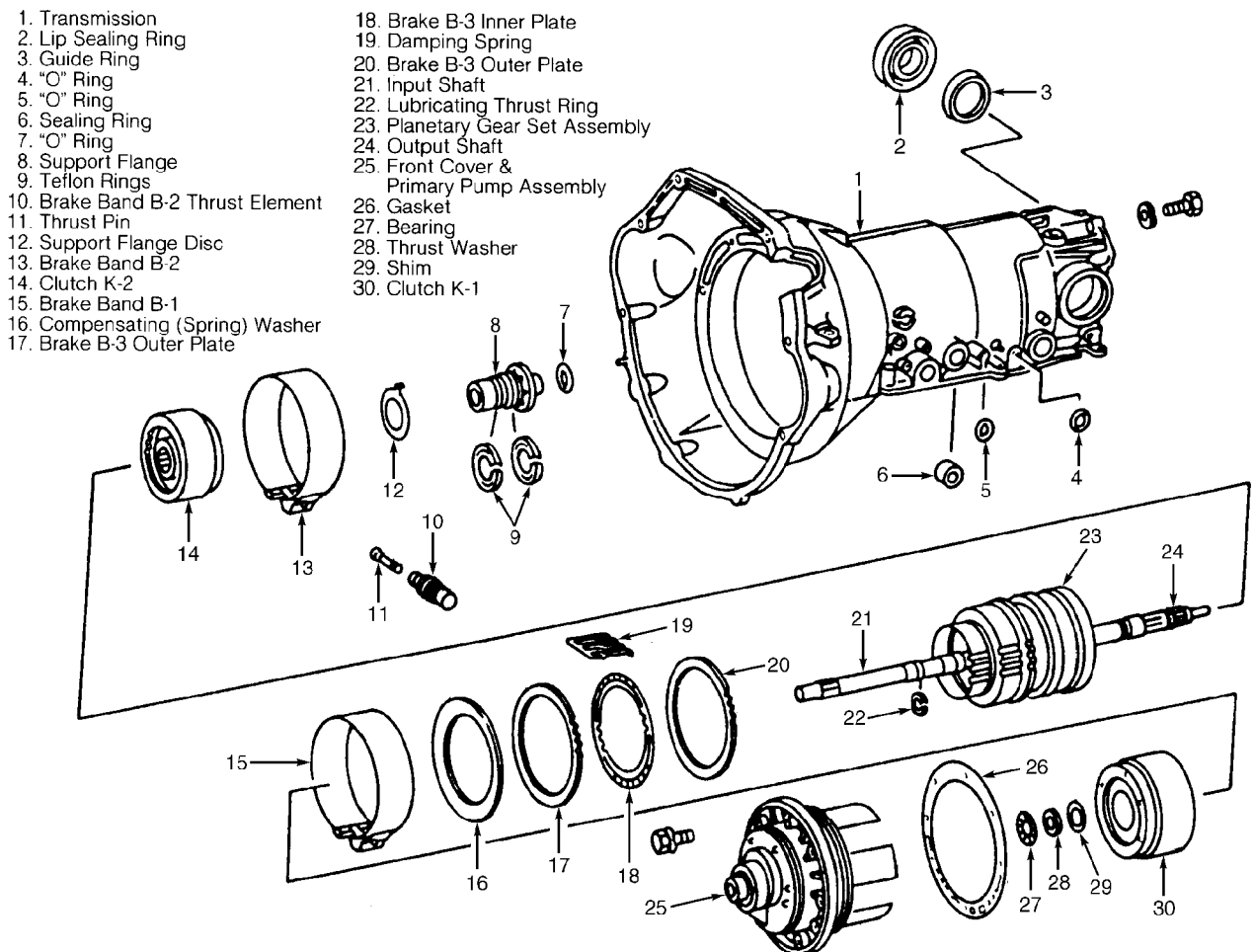

93A24R36
Fig. 8: Exploded View Of Front Cover, Planetary Gear Set, Clutch & Brake Band Assemblies (722.3 & 722.4 Series)
Courtesy of Mercedes-Benz of North America.

722.5 SERIES

1) Remove control pressure cable sleeve by pressing tab inward, turning cable counterclockwise 90 degrees, and pulling sleeve upward. Detach selector lever cable by releasing locking device with a screwdriver. Remove shift point retard switchover valve from

AUTO TRANS DIAGNOSIS - 722 SERIES

Article Text (p. 24)

1996 Mercedes-Benz C220

Copyright © 1998 Mitchell Repair Information Company, LLC
Wednesday, January 26, 2000 12:03PM

transmission.

2) Position transmission in holding fixture and mounting plate with oil pan facing upward. Remove oil pan and gasket. Remove oil filter and valve body, noting length and location of valve body bolts. Remove leaf spring and bracket. See Fig. 9. Remove lower cover, intermediate plate and oil pipe assembly.

3) Remove vacuum modulator valve securing bracket bolts and vacuum modulator valve. See Fig. 10. Remove starter lock-out switch. Remove secondary pump and transmission vent. Install 2 long bolts into threaded holes in front cover. Tighten bolts to pull out cover. Remove bolts and front cover assembly.

4) Engage parking lock mechanism and remove output shaft nut. Remove 3-arm flange from output shaft. Remove locking ring, governor cover, and governor assembly. Attach assembly fixture to transmission housing. Remove rear cover.

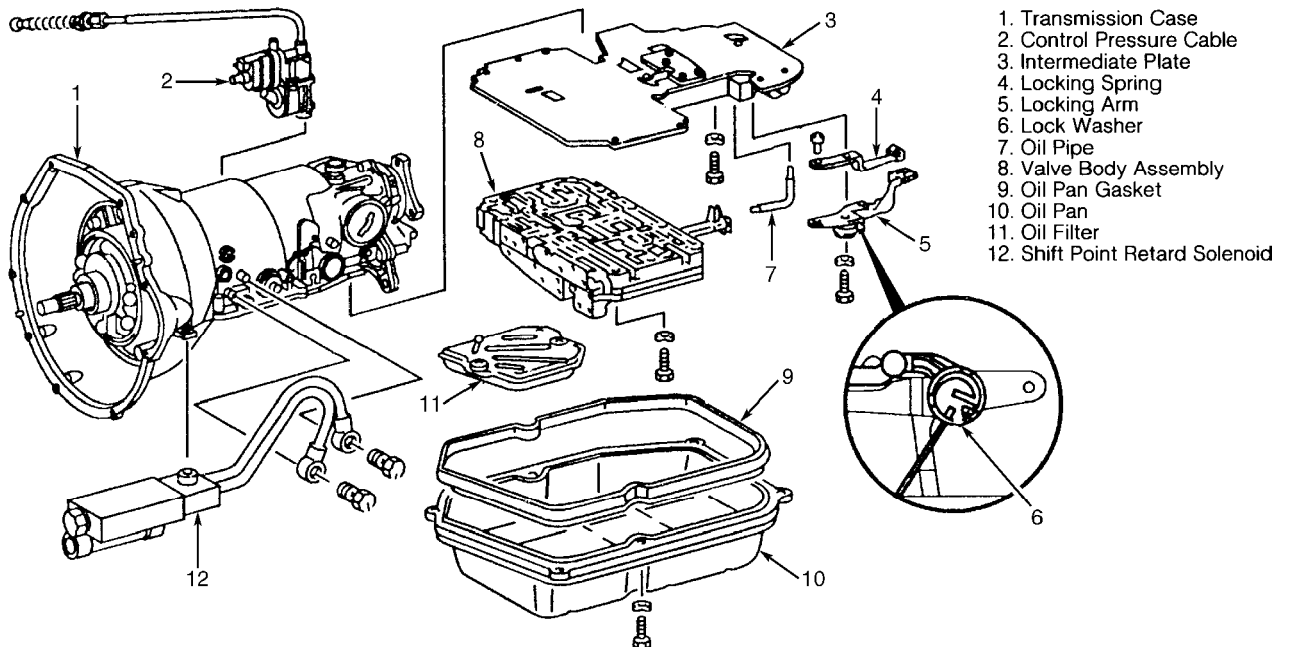

96B30859

Fig. 9: Exploded View Of Transmission Case External Components
(722.5 Series)

Courtesy of Mercedes-Benz of North America.

AUTO TRANS DIAGNOSIS - 722 SERIES

Article Text (p. 25)

1996 Mercedes-Benz C220

Copyright © 1998 Mitchell Repair Information Company, LLC
Wednesday, January 26, 2000 12:03PM

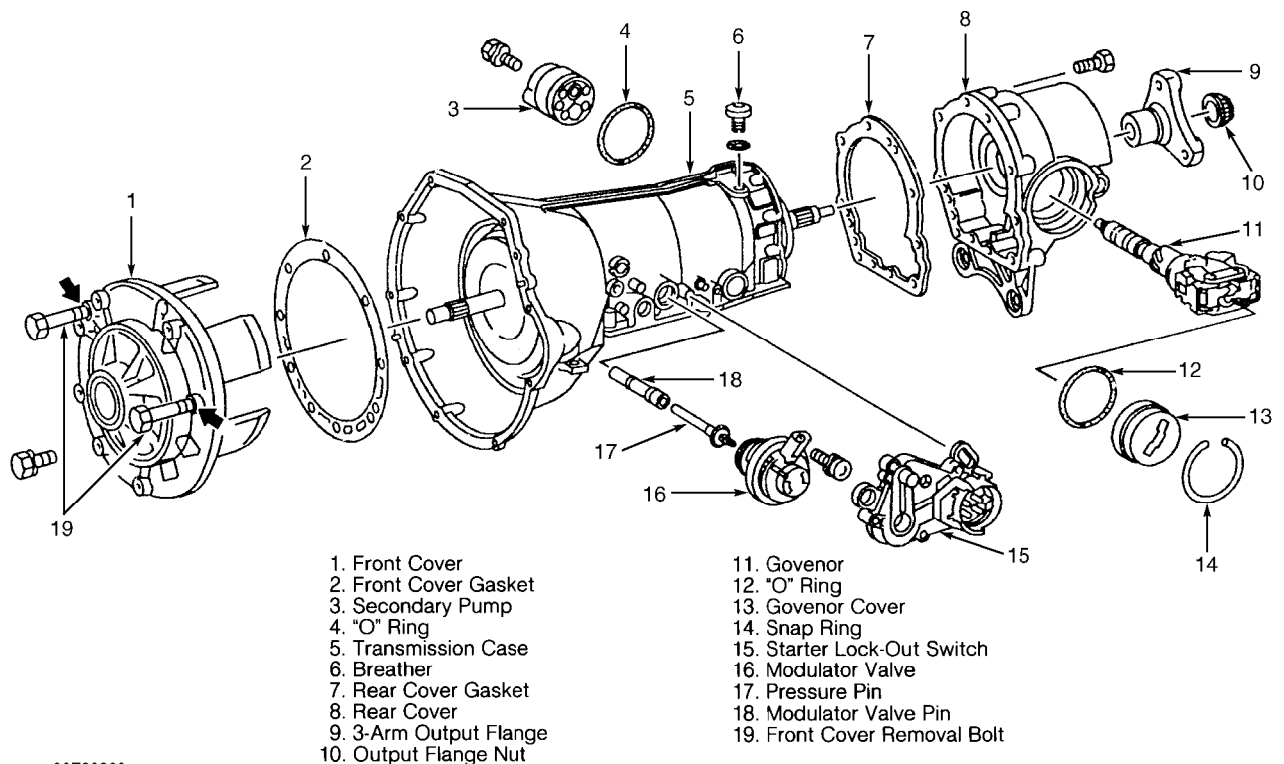

Fig. 10: Exploded View Of Transmission Rear Cover, Governor & Secondary Pump Assemblies (722.5 Series)
Courtesy of Mercedes-Benz of North America.

CAUTION: Do not face torque converter housing downwards while removing overdrive brake and overdrive clutch. Components will fall out causing damage to components.

5) Remove spring and parking lock pawl. See Fig. 11. Remove plastic parking lock pawl guide and detent assembly. Remove electrical connector for kick-down solenoid valve. Remove snap ring and output shaft with planetary gear set. Remove 2nd one-way clutch and overdrive clutch assemblies.

6) Remove snap ring securing overdrive brake assembly. Remove friction and steel plates. Remove overdrive brake piston and damper spring. Remove overload switch (or bolt if not equipped with overload switch) and remove brake band thrust pin.

7) Compress brake band B-1 piston cover and remove snap ring. See Fig. 12. Loosen assembly fixture and remove brake band B-1 piston cover. Remove brake band B-1 piston and return springs. Remove brake band B-1 guide. Remove input shaft with brake band B-1, clutch K-1 and brake B-1 assembly attached.

8) Remove damper spring. Compress brake band B-2 as much as possible and remove snap ring. Remove brake band piston. Remove brake band B-2 thrust element. Remove "O" rings, sealing rings, and aluminum sealing rings from transmission housing.

9) Remove clutch K-2 and brake band B-2 from transmission housing. Remove plastic ring guide and seal. Remove thrust washers from support flange. Remove securing bolts and support flange.

AUTO TRANS DIAGNOSIS - 722 SERIES

Article Text (p. 26)

1996 Mercedes-Benz C220

Copyright © 1998 Mitchell Repair Information Company, LLC
 Wednesday, January 26, 2000 12:03PM

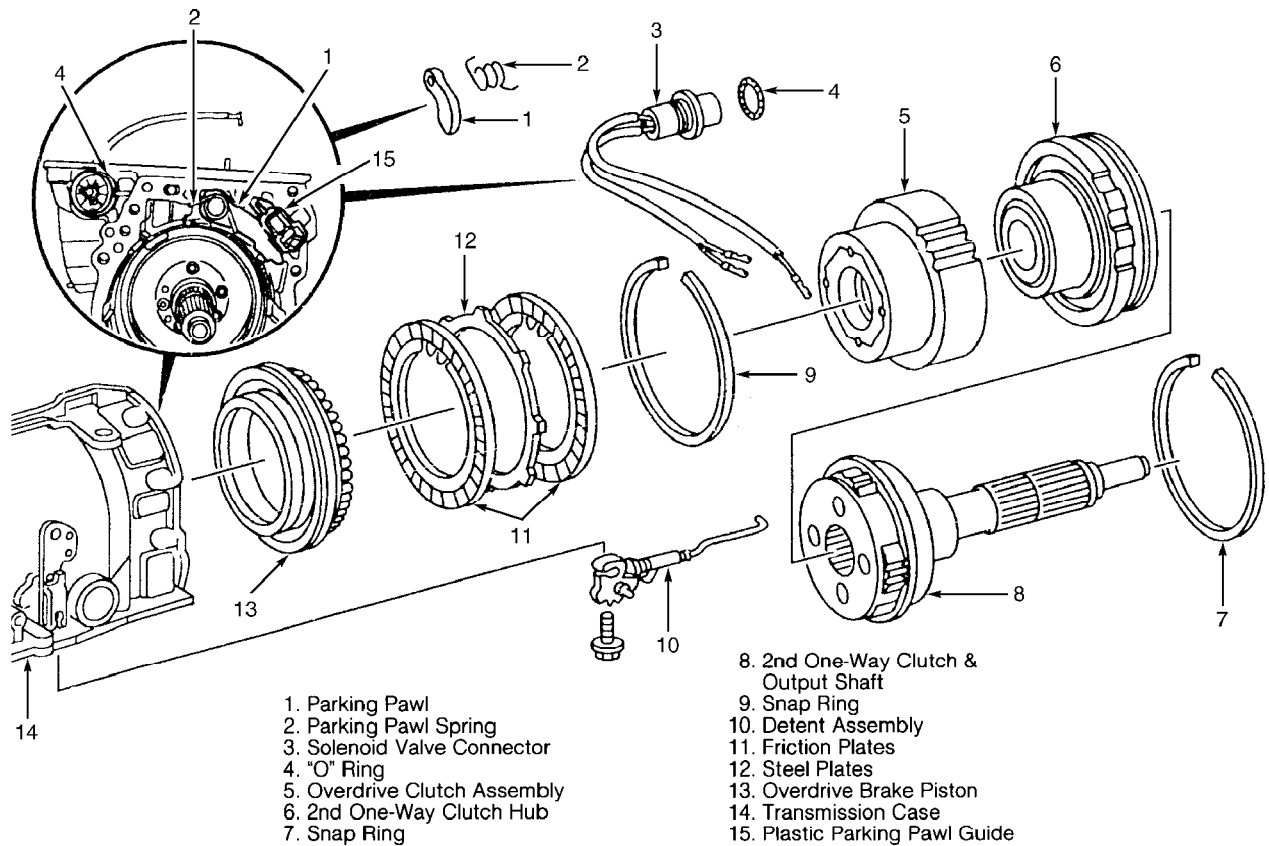

96F30861

Fig. 11: Exploded View Of Overdrive Clutch & Brake Band Assemblies (722.5 Series)

Courtesy of Mercedes-Benz of North America.

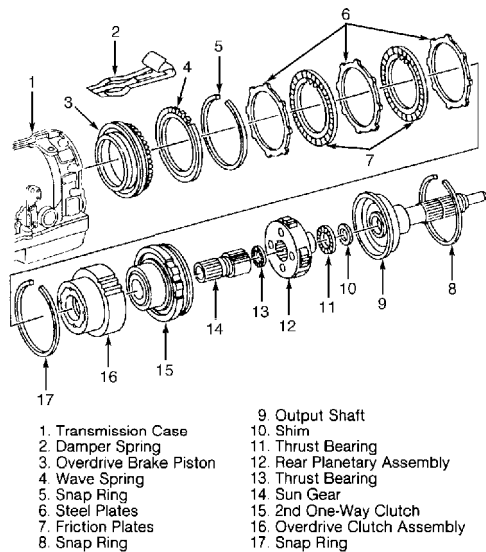

96G30862

Fig. 12: Exploded View Of Overdrive Brake & 2nd One-Way Clutch (722.5 Series)

Courtesy of Mercedes-Benz of North America.

AUTO TRANS DIAGNOSIS - 722 SERIES

Article Text (p. 27)

1996 Mercedes-Benz C220

Copyright © 1998 Mitchell Repair Information Company, LLC
Wednesday, January 26, 2000 12:03PM

COMPONENT DISASSEMBLY & REASSEMBLY

VALVE BODY

Disassembly

1) Remove 2 screws at arrows, plate check valve and strainer. See Fig. 13. Hold damper housing and valve body together and turn over. Carefully remove damper housing and intermediate plate from valve body. Note direction and location of retainers, springs and check valves.

2) Remove check balls from valve body, noting number (18 or 19), type, size and location for reassembly reference. See Fig. 14. Remove side covers, control valves, pistons and springs. See Figs. 15 and 16.

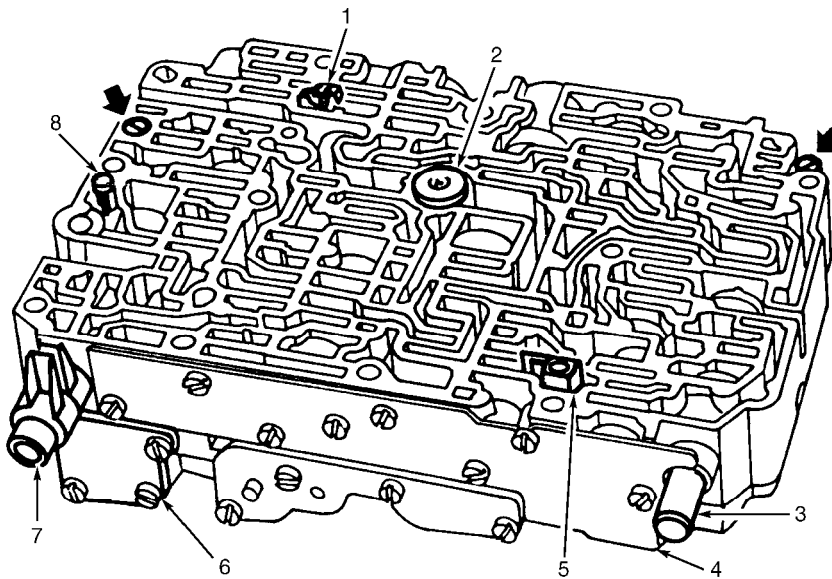

1. Reed-Type Check Valve (With Bore)
2. Primary Pump Check Valve
3. Control Pressure Regulating Valve Plunger
4. Valve Body Housing
5. Brake Band B-2 Shift Valve Strainer
6. Damper Housing
7. Range (Gear) Selector Valve
8. Drain Valve

93R24837

Fig. 13: Assembled View Of Valve Body & Damper Housing
Courtesy of Mercedes-Benz of North America.

AUTO TRANS DIAGNOSIS - 722 SERIES

Article Text (p. 28)

1996 Mercedes-Benz C220

Copyright © 1998 Mitchell Repair Information Company, LLC
Wednesday, January 26, 2000 12:03PM

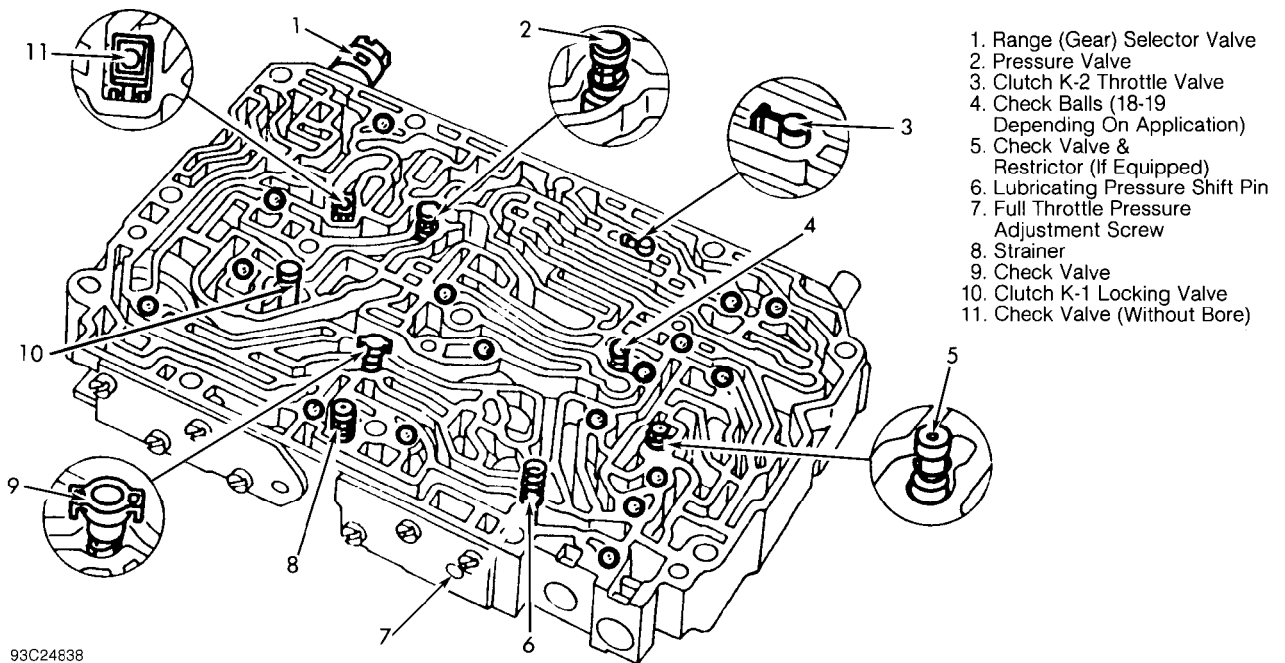

93C24838

Fig. 14: Exploded View Of Valve Body (Check Ball & Check Valve Locations)

Courtesy of Mercedes-Benz of North America.

Inspection

1) Wash all parts in clean solvent and blow dry with compressed air. Closely inspect valve body and pick-up housing passages for obstructions or defects.

2) Inspect intermediate plate for damage. Inspect check balls for damage. If internal valve body problems are found or suspected, valve body must be replaced as an assembly.

Reassembly

To reassemble valve body, reverse order of disassembly. Check ball rests on a conical spring. See Fig. 14. Tighten valve body screws at arrows so damper housing and valve body may be shifted in relation to each other. Rotating full throttle pressure adjustment screw clockwise produces earlier full throttle or kickdown upshifts; counterclockwise rotation of screw delays upshifts. See Fig. 14.

AUTO TRANS DIAGNOSIS - 722 SERIES

Article Text (p. 29)

1996 Mercedes-Benz C220

Copyright © 1998 Mitchell Repair Information Company, LLC
 Wednesday, January 26, 2000 12:03PM

1. Clutch K-1 Locking Valve
2. Range (Gear) Selector Valve
3. Torque Converter Control Valve
4. 3-4 Command Valve Piston
5. 3-4 Command Valve
6. 1-2 Command Valve
7. 1-2 Command Valve Sleeve
8. 1-2 Command Valve Piston
9. Lock-Up Clutch Shift Valve
10. Kickdown Shift Valve
11. Brake Band B-2 Shift Valve
12. Governor Pressure Shift Valve
13. Controlled Pressure Control Valve
14. Controlled Pressure Control Valve Piston
15. Lubricating Pressure Shift Pin

16. Governor Pressure Booster Valve
17. Brake Band B-1 Control Valve
18. Brake Band B-1 Control Valve Piston
19. Throttle Control Valve
20. Working Pressure Control Valve
21. Basic Pressure Control Valve
22. Brake Band B-1 Shift Valve
23. 2-3 Command Valve Piston
24. 2-3 Command Valve

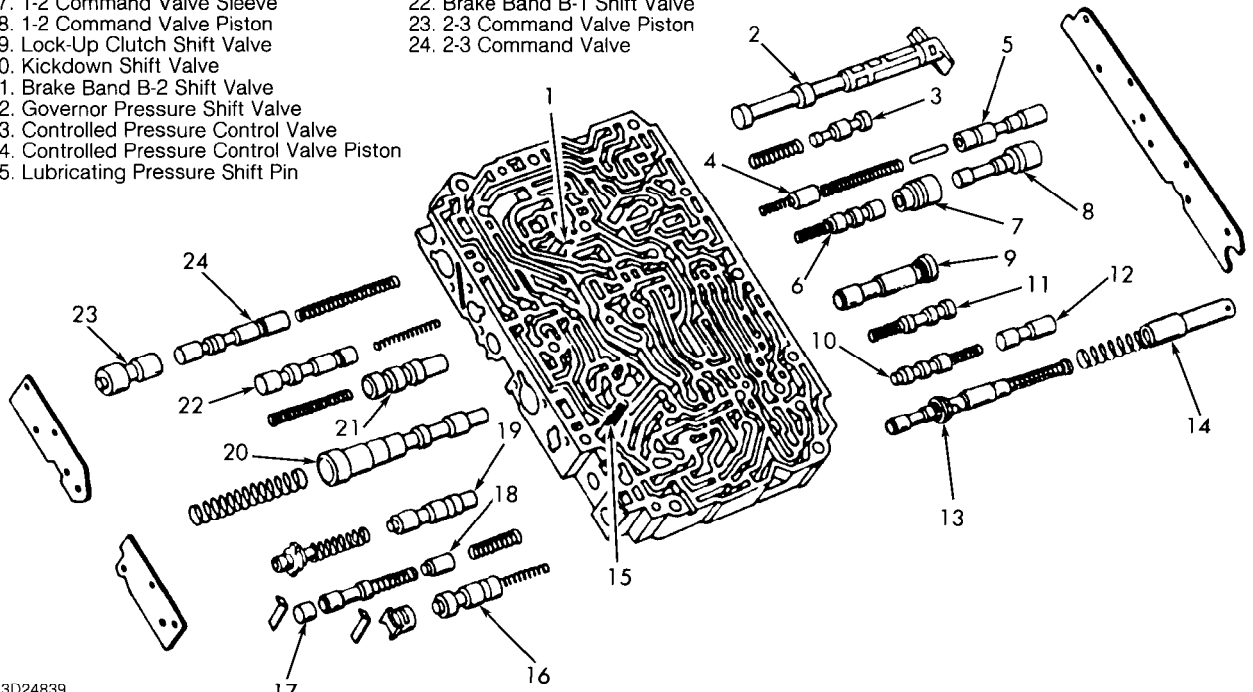

93D24839

Fig. 15: Exploded View Of Valve Body
 Courtesy of Mercedes-Benz of North America.

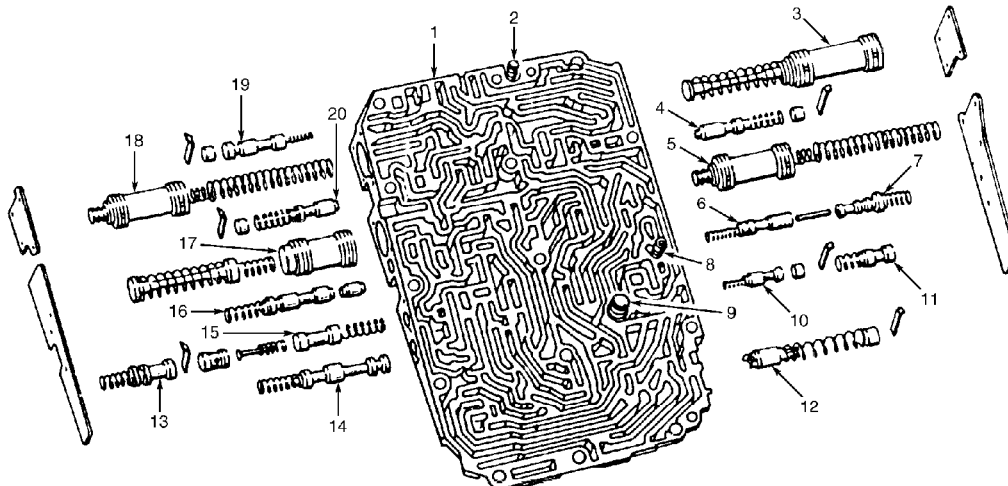

1. Damper Housing
2. Pressure Limiting Valve
3. Clutch K-1 Damper
4. Clutch K-1 Damper Control Valve
5. Brake Band B-1 Damper
6. Brake Band B-1 Damper Control Valve
7. Deceleration (Fuel Cut-Off) Shift Valve

8. Modulating Pressure Valve
9. Lubricating Pressure Valve
10. Reverse (RV1) Shut-Off Valve
11. Braking Shift Shut-Off Valve
12. Kickdown Damper
13. Clutch K-2 Shift Valve
14. Brake Band B-2 Detent Valve

15. Damper (Cut-In) Switching Control Valve
16. Reverse (RV2) Shut-Off Valve
17. Damper (Cut-In) Switching Valve
18. Clutch K-2 Damper
19. Shift Pressure Control Valve
20. Clutch K-2 Damper Control Valve

93G24840

Fig. 16: Exploded View Of Damper Housing
 Courtesy of Mercedes-Benz of North America.

AUTO TRANS DIAGNOSIS - 722 SERIES

Article Text (p. 30)

1996 Mercedes-Benz C220

Copyright © 1998 Mitchell Repair Information Company, LLC
Wednesday, January 26, 2000 12:03PM

LOWER COVER

NOTE: If installed, note location of temperature restrictor, deflector piece, and locating pin after removing lower cover and intermediate plate. An auxiliary restrictor may also be installed.

Disassembly

1) Remove valve body and oil filter (if installed). Remove leaf spring and bracket. See Figs. 17 and 18. Remove lower cover, intermediate plate and oil pipe as an assembly.

2) Press injector tabs inward and remove injector. Pull out oil tube. Remove cover plate and intermediate plate. Remove gasket from intermediate plate. Remove "E" ring, plug, spring and secondary pump shift valve. Remove "E" clip, bushing, spring, pin and shutoff valve.

Inspection

Ensure cover and intermediate plates are not plugged or distorted. Inspect secondary pump shift valve, shutoff valve and springs for damage.

Reassembly

To reassemble lower cover, reverse order of disassembly. Ensure locating pin for detent spring bracket is correctly inserted. Ensure temperature restrictor, deflector piece, locating pin and auxiliary restrictor are properly installed.

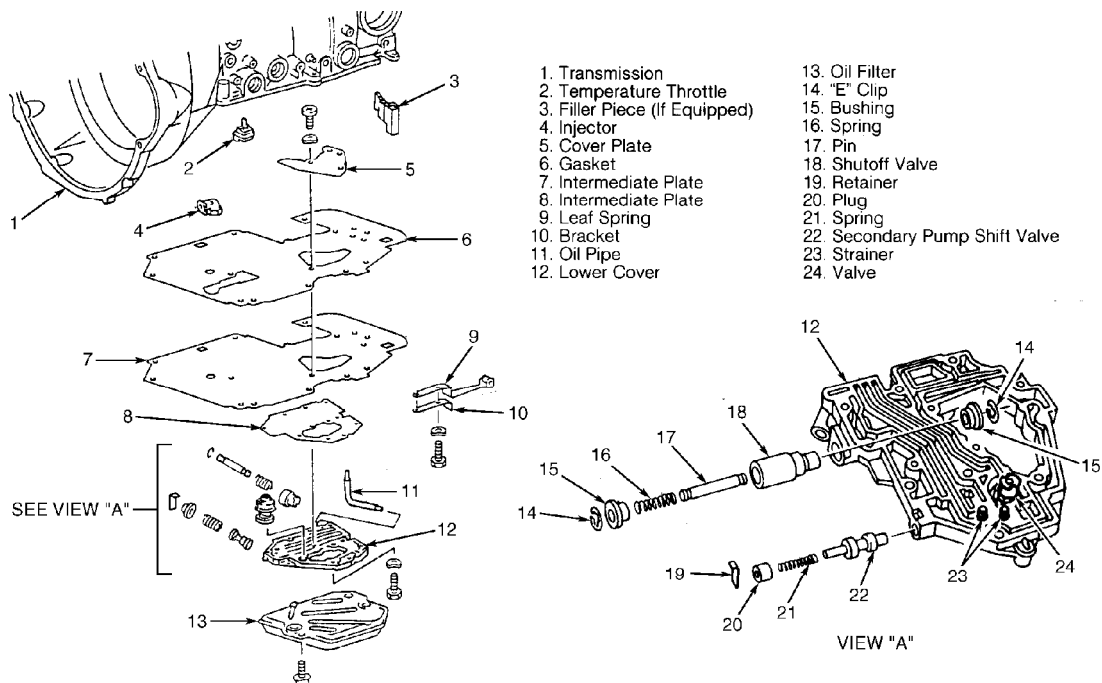

93H24841
Fig. 17: Exploded View Of Lower Cover (722.3 & 722.4 Series)
Courtesy of Mercedes-Benz of North America.

AUTO TRANS DIAGNOSIS - 722 SERIES

Article Text (p. 31)

1996 Mercedes-Benz C220

Copyright © 1998 Mitchell Repair Information Company, LLC
Wednesday, January 26, 2000 12:03PM

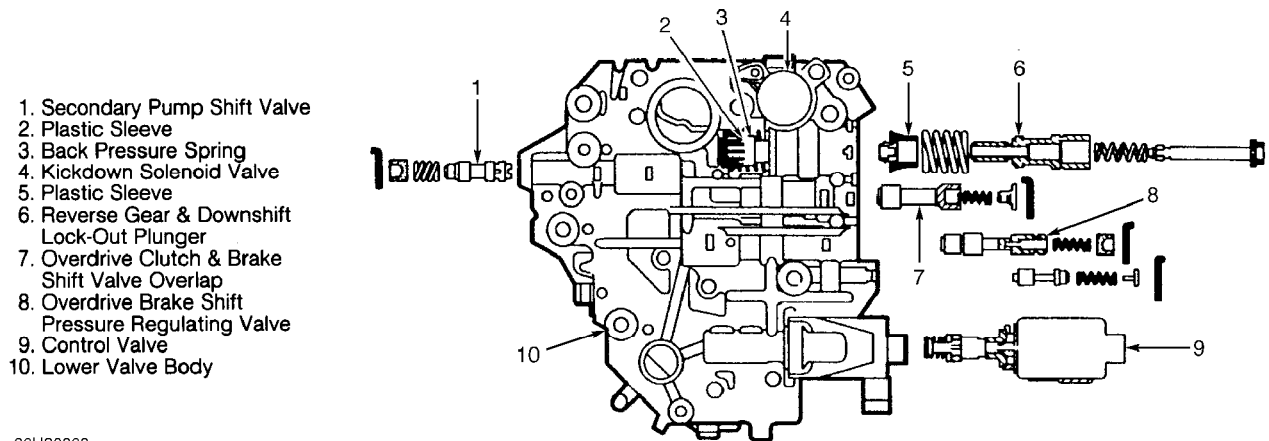

96H30863
Fig. 18: Exploded View Of Lower Cover (722.5 Series)
Courtesy of Mercedes-Benz of North America.

REAR COVER

Disassembly & Reassembly

1) Pry out rear cover seal. Remove snap ring and press out bearing. Using drift pin, drive speedometer gear and shaft from rear cover. Screw 12-mm bolt into radial seal ring. Using a plastic hammer, apply light blows to bolt to remove radial seal ring. Remove oil accumulator from rear cover.

2) To reassemble, reverse disassembly procedure. Using a .004" (.10 mm) feeler gauge, measure clearance between snap ring and bearing. There should be no play between snap ring and bearing.

3) Snap ring is available in thicknesses of .079-.090" (2.00-2.30 mm) in increments of .004" (.10 mm). When inserting replacement snap ring, ensure it is correctly seated in groove. If snap ring cannot be inserted, use a thinner snap ring.

SECONDARY PUMP

Disassembly

Remove gears from pump housing. See Fig. 19. Remove shutoff piston cover retaining ring and cover. Remove shutoff piston, compression spring and spring retainer from pump housing.

Inspection

Check gears and pump housing for damage or unusual wear. Check compression spring for distortion. Check shutoff piston and Teflon ring for damage, and replace as necessary.

Reassembly

Install "O" ring in pump housing. Install Teflon ring on shutoff piston. Install shutoff piston into pump housing. Install compression spring and spring retainer into shutoff piston. Install piston cover and piston cover retaining ring. Lubricate gears and place in pump housing.

AUTO TRANS DIAGNOSIS - 722 SERIES

Article Text (p. 32)

1996 Mercedes-Benz C220

Copyright © 1998 Mitchell Repair Information Company, LLC
Wednesday, January 26, 2000 12:03PM

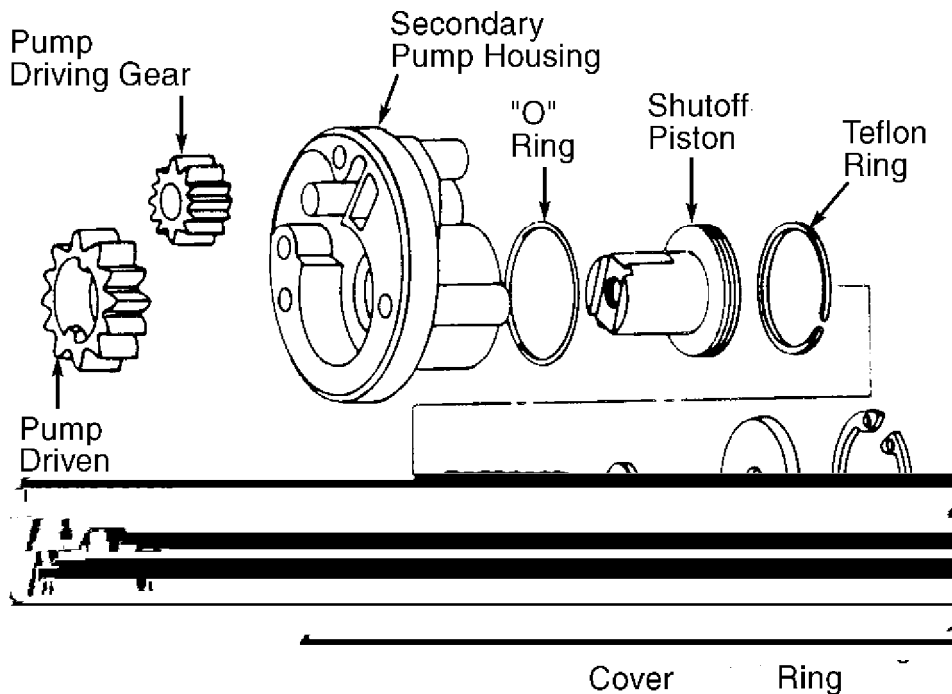

93124842

Fig. 19: Exploded View Of Secondary Pump
Courtesy of Mercedes-Benz of North America.

PRIMARY PUMP

Disassembly

- 1) Remove 2 Teflon seals from stator shaft. Using appropriate spring compressor, compress spring retainer and remove snap ring. Remove spring retainer and springs for brake B-3 piston.
- 2) Remove brake B-3 piston. Remove pump housing bolts and lift primary pump from transmission front cover. Remove gears from pump housing. See Fig. 20.

Inspection

Check bearing for scoring or damage. Check seal for damage. Check "O" ring for correct installation in groove. Check pump gears for scoring or damage.

Reassembly

- 1) Lubricate and install gears into pump housing. Ensure chamfered edge of driven gear faces down in pump housing. See Fig. 21.
- 2) Install intermediate plate on primary pump assembly. Install primary pump housing onto pump cover, being careful not to damage bearing on stator shaft. Install primary pump bolts.
- 3) Install sealing rings on brake B-3 piston, with lip of sealing rings facing downward. Place Insertion Sleeve (126589041400) on pump cover. Lubricate sealing rings. Install piston over insertion sleeve with pin on piston lining up with bore in pump cover. Carefully install brake B-3 piston. See Fig. 20.
- 4) Install springs and spring retainer. Slide snap ring over

AUTO TRANS DIAGNOSIS - 722 SERIES

Article Text (p. 33)

1996 Mercedes-Benz C220

Copyright © 1998 Mitchell Repair Information Company, LLC
Wednesday, January 26, 2000 12:03PM

insertion sleeve. Hold snap ring at bottom of sleeve and remove sleeve. Using appropriate spring compressor, compress spring retainer and install snap ring. Ensure snap ring seats in groove. Install Teflon seals on stator shaft.

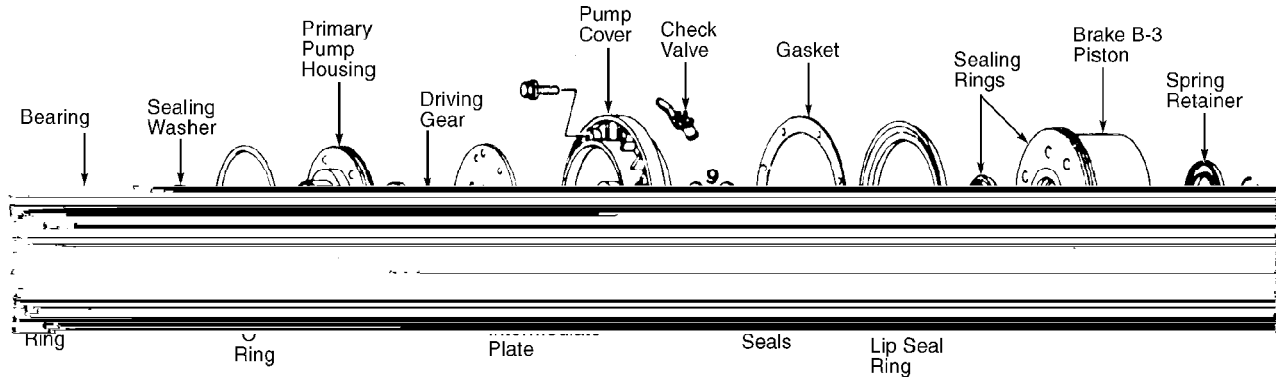

93A24844
Fig. 20: Exploded View Of Primary Pump
Courtesy of Mercedes-Benz of North America.

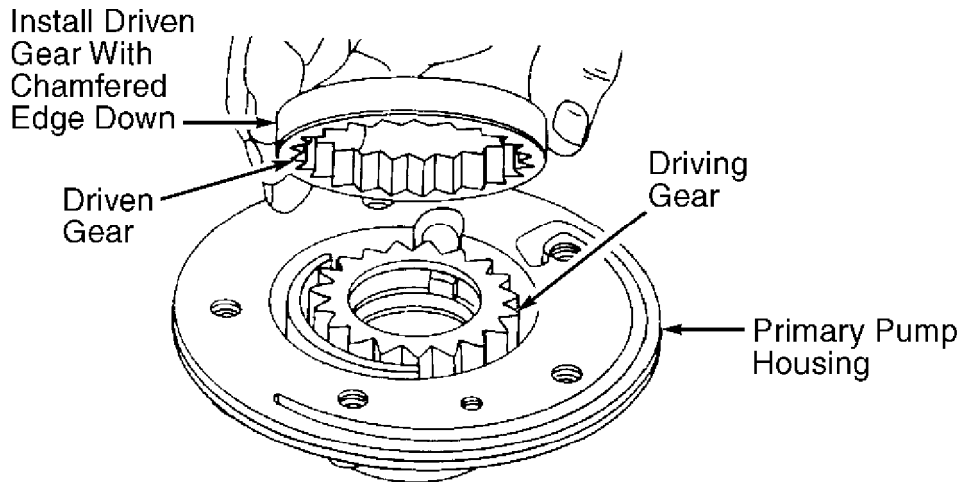

93J24843
Fig. 21: Installing Primary Pump Driven Gear
Courtesy of Mercedes-Benz of North America.

PLANETARY GEAR SET

Disassembly

1) Position assembly fixture with plate facing upward. Place planetary gear set on assembly fixture with input shaft pointing upward. Remove lubrication thrust ring(s). See Fig. 22. Remove snap ring retaining front planetary gear set. Lift front planetary gear set off input shaft.

2) Remove axial bearing and input shaft. Remove radial bearing and axial bearing. Remove output shaft. Remove axial bearing and sun gear. See Fig. 22. Remove snap ring retaining clutch K-2 in plate carrier.

3) Remove inner plate carrier with one-way clutch from

AUTO TRANS DIAGNOSIS - 722 SERIES

Article Text (p. 34)

1996 Mercedes-Benz C220

Copyright © 1998 Mitchell Repair Information Company, LLC
Wednesday, January 26, 2000 12:03PM

connecting carrier. Remove support disc, compensating ring and "O" ring from one-way clutch. Rotate inner race of one-way clutch in counterclockwise direction and pull out inner race. Remove one-way clutch and rollers.

Inspection

Check bearing surfaces and bearing races for scoring or damage. Check one-way clutch roller bearings for scoring, roundness and wear. If one-way clutch rollers are damaged, replace one-way clutch as an assembly. Lubricate bearings with ATF during assembly.

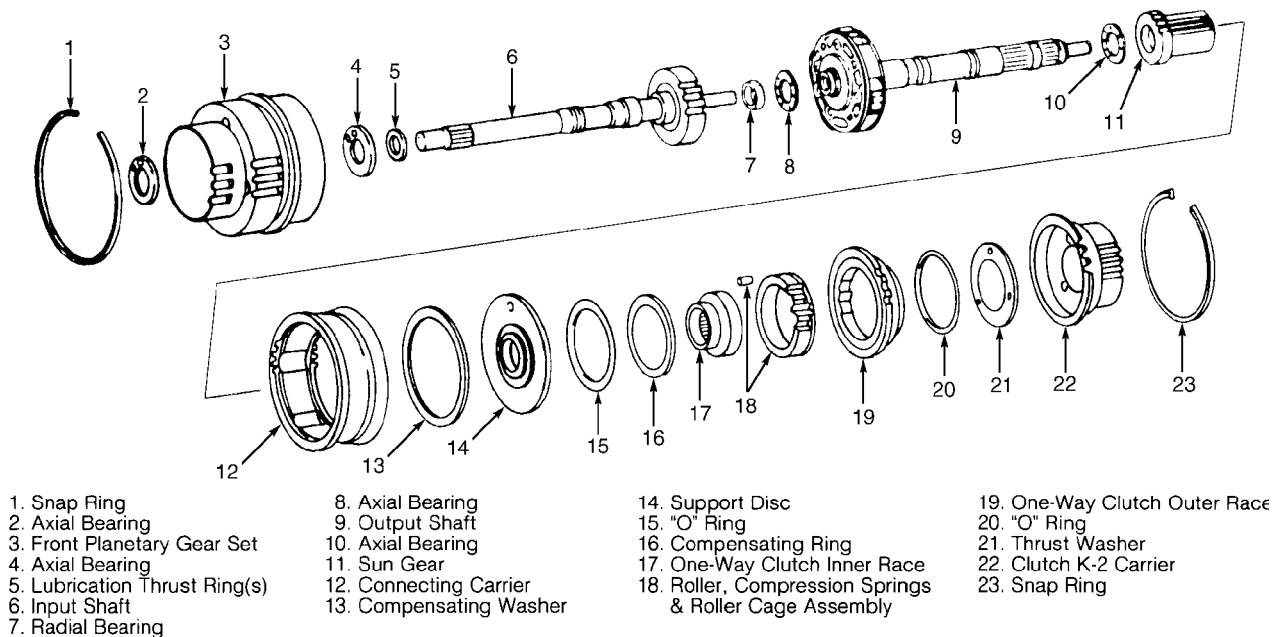

93R24R45
Fig. 22: Exploded View Of Planetary Gear Set
Courtesy of Mercedes-Benz of North America.

Reassembly

1) To reassemble planetary gear set, reverse order of disassembly. Install one-way clutch outer race on inner plate carrier and insert roller cage. Press rollers against compression springs and insert retainer plates with rounded edge pointing outward. See Fig. 23.

2) Install one-way clutch inner race while rotating counterclockwise. Pull out retainer plates. Install compensating ring. Install support disc so pin enters bore of one-way clutch outer race. See Fig. 24.

3) Install compensating ring into connecting carrier. Hold one-way clutch together and place assembly into connecting carrier. Install snap ring and push into groove with screwdriver.

4) With one-way clutch "O" ring removed, check clearance between one-way clutch and connecting carrier. See Fig. 25. Clearance should be .002-.008" (.05-.20 mm). If clearance is incorrect, add or remove compensating shim(s) until clearance is within specifications. If clearance is correct, install one-way clutch "O" ring.

AUTO TRANS DIAGNOSIS - 722 SERIES

Article Text (p. 35)

1996 Mercedes-Benz C220

Copyright © 1998 Mitchell Repair Information Company, LLC
Wednesday, January 26, 2000 12:03PM

5) Insert sun gear into one-way clutch assembly. One-way clutch should lock when sun gear is rotated in clockwise direction. Install axial bearing on sun gear. Place one-way clutch on assembly fixture and install output shaft. Install axial and radial bearings on output shaft.

6) Install input shaft and axial bearing. Install front planetary gear set and secure by pushing snap ring into groove. Install lubrication thrust ring(s) into groove. Remove planetary gear set from assembly fixture.

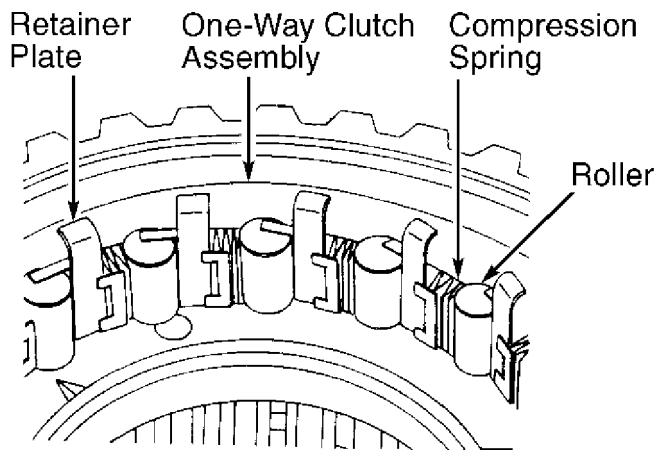

93F24872

Fig. 23: Installing One-Way Clutch Rollers
Courtesy of Mercedes-Benz of North America.

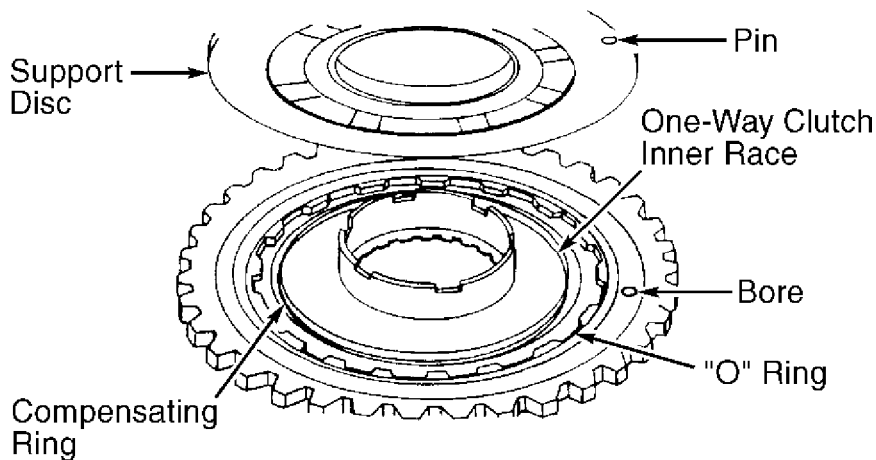

93G24873

Fig. 24: Installing One-Way Clutch Support Disc
Courtesy of Mercedes-Benz of North America.

AUTO TRANS DIAGNOSIS - 722 SERIES

Article Text (p. 36)

1996 Mercedes-Benz C220

Copyright © 1998 Mitchell Repair Information Company, LLC
Wednesday, January 26, 2000 12:03PM

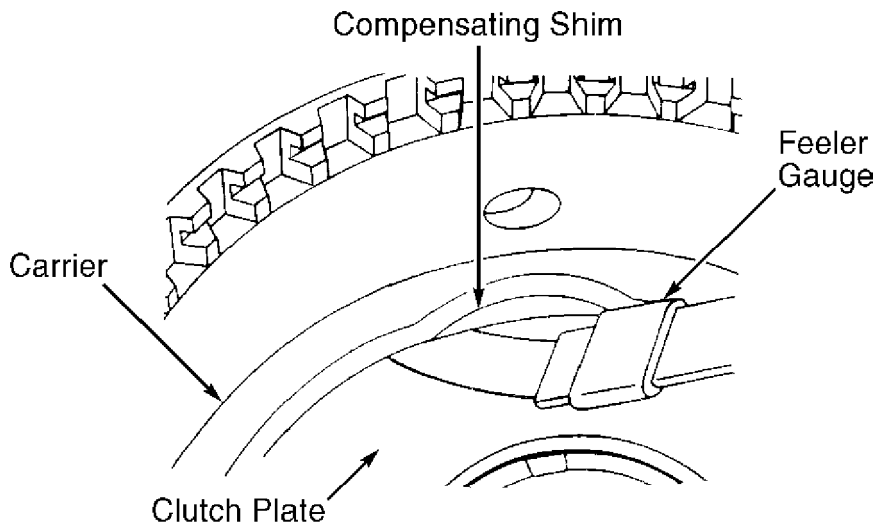

93H24874

Fig. 25: Measuring One-Way Clutch Clearance
Courtesy of Mercedes-Benz of North America.

CLUTCH K-1

Disassembly

1) Remove snap ring retaining clutch pack in plate carrier. Remove clutch pack and spring washer. Install appropriate spring compressor on spring retainer and compress until snap ring is exposed. Remove snap ring.

2) Release pressure from spring compressor and remove. Remove spring retainer and compression springs. Remove piston from plate carrier. See Fig. 26. Remove snap ring, piston guide and "O" ring (if equipped).

Reassembly

1) Install NEW sealing rings on piston with lip of sealing rings pointing toward flat surface of piston. Place Installation Sleeves (126589021400 and 126589031400) on plate carrier.

2) Lubricate installation sleeves and sealing rings with ATF. Install piston into plate carrier. Ensure piston is centered in carrier. Remove installation sleeves.

3) Install compression springs into piston. Install spring retainer. Ensure each compression spring is centered by a guide pin. Install spring compressor and compress springs. Install snap ring and release compressor. Ensure snap ring is properly seated in groove. Remove spring compressor.

4) Soak inner clutch plates in ATF for at least one hour. Install clutch plates in plate carrier. See Fig. 28. Install snap ring. Ensure snap ring is fully seated in groove.

5) With a screwdriver on top outer plate, force snap ring upward along entire circumference of plate carrier. Check clutch pack end play between top outer plate and snap ring.

6) End play should be .028-.051" (.70-1.30 mm). If necessary, adjust end play by changing snap ring. If correct clearance cannot be

AUTO TRANS DIAGNOSIS - 722 SERIES

Article Text (p. 37)

1996 Mercedes-Benz C220

Copyright © 1998 Mitchell Repair Information Company, LLC
 Wednesday, January 26, 2000 12:03PM

obtained by changing snap ring, change thickness of outer clutchplate(s).

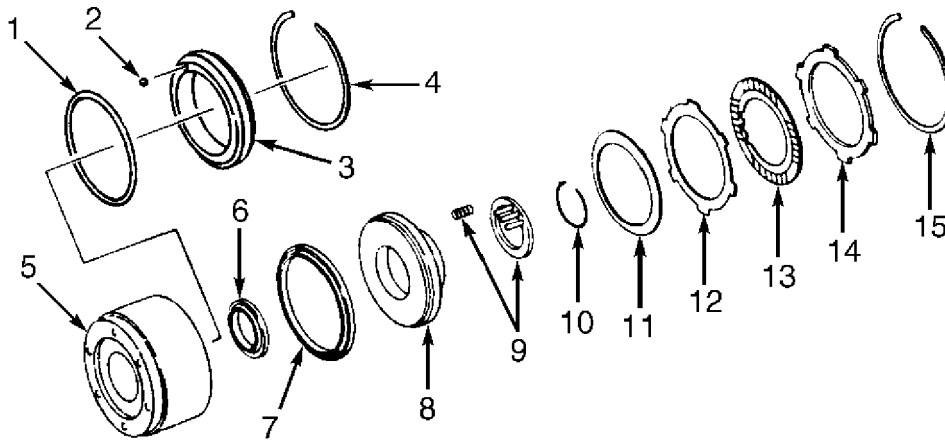

- | | |
|---------------------------|---|
| 1. "O" Ring | 9. Compression Spring & Spring Retainer |
| 2. Check Ball | 10. Snap Ring |
| 3. Piston Guide | 11. Spring Washer |
| 4. Snap Ring | 12. Outer Clutch Plate |
| 5. Plate Carrier | 13. Inner Clutch Plate |
| 6. Inner Lip Sealing Ring | 14. Outer Clutch Plate |
| 7. Outer Lip Sealing Ring | 15. Snap Ring |
| 8. Clutch Piston | |

93124875
 Fig. 26: Exploded View Of K-1 Clutch
 Courtesy of Mercedes-Benz of North America.

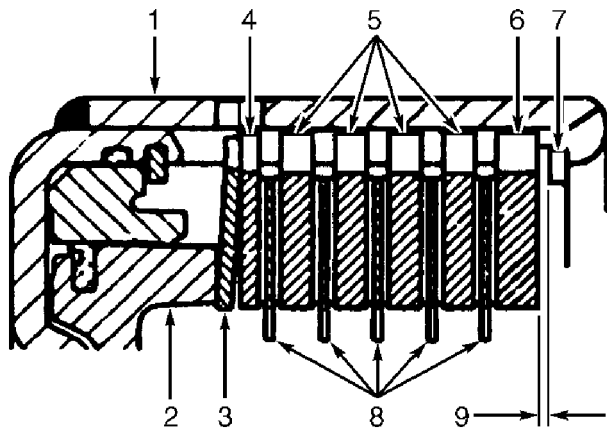

- | | |
|----------------------|-----------------------|
| 1. Clutch Carrier | 6. Outer Steel Plate |
| 2. Clutch Piston | 7. Snap Ring |
| 3. Wave Spring | 8. Friction Plate |
| 4. Inner Steel Plate | 9. Measured Clearance |
| 5. Steel Plate | |

96130864
 Fig. 27: Installing K-1 Clutch Pack
 Courtesy of Mercedes-Benz of North America.

AUTO TRANS DIAGNOSIS - 722 SERIES

Article Text (p. 38)

1996 Mercedes-Benz C220

Copyright © 1998 Mitchell Repair Information Company, LLC
Wednesday, January 26, 2000 12:03PM

CLUTCH K-2

Disassembly

1) Remove snap ring retaining clutch pack in plate carrier. Tilt plate carrier and remove clutch pack. Install appropriate spring compressor on spring retainer and compress until snap ring is exposed.

2) Remove snap ring. Release pressure from spring compressor and remove. Remove spring retainer and compression springs. Remove piston from plate carrier. See Fig. 28.

Reassembly

1) Install NEW sealing rings on piston with lip of sealing rings pointing downward (away from piston flange). On 722.3 Series transmissions, place Installation Sleeve (126589021400) on center hub of plate carrier. On 722.4 and 722.5 Series transmissions, place Installation Sleeve (140589001400) on center hub of plate carrier.

2) On all models, lubricate installation sleeve (if used) and clutch piston sealing rings with ATF. Carefully place clutch piston over installation sleeve and slide piston onto plate carrier. Ensure piston is centered in carrier. Remove installation sleeve.

3) Install compression springs on clutch piston. Install spring retainer with spring centered by guide pin. Install spring compressor on spring retainer. Compress spring retainer and install snap ring. Ensure snap ring is fully seated in groove.

4) Remove compressor. Soak inner clutch plates in ATF for at least one hour. Install clutch plates in plate carrier. See Fig. 29. Install snap ring. Ensure snap ring is fully seated in groove.

5) With a screwdriver against top outer plate, force snap ring upward along entire circumference of plate carrier. Using a feeler gauge, check clutch pack end play between top outer plate and snap ring.

6) End play should be .028-.051" (.70-1.30 mm). If necessary, adjust end play by changing snap ring. If correct clearance cannot be obtained by changing snap ring, change thickness of outer clutchplate(s).

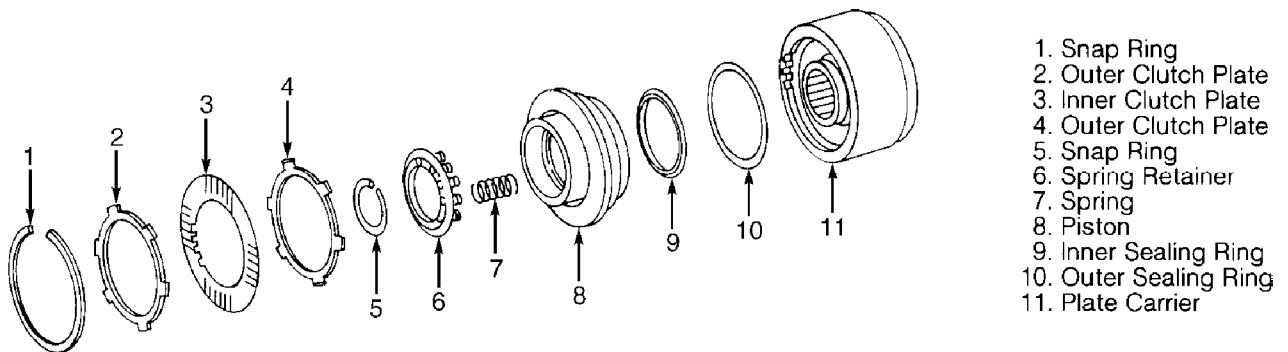

Fig. 28: Exploded View Of K-2 Clutch
Courtesy of Mercedes-Benz of North America.

AUTO TRANS DIAGNOSIS - 722 SERIES

Article Text (p. 39)

1996 Mercedes-Benz C220

Copyright © 1998 Mitchell Repair Information Company, LLC
Wednesday, January 26, 2000 12:03PM

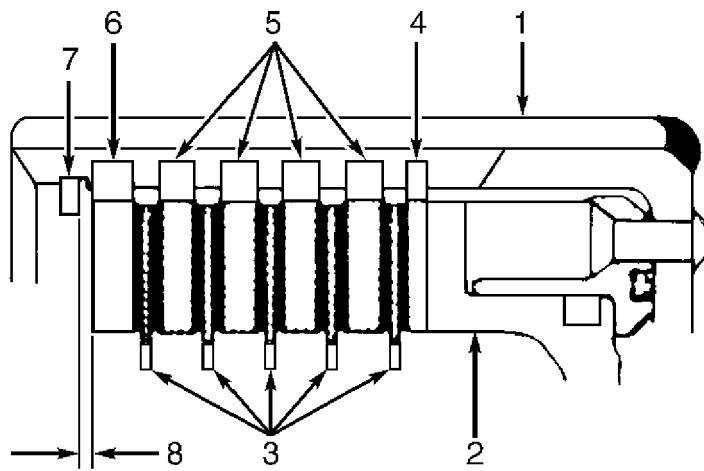

- | | |
|----------------------|-----------------------|
| 1. Clutch Carrier | 5. Steel Plate |
| 2. Clutch Piston | 6. Outer Steel Plate |
| 3. Friction Plate | 7. Snap Ring |
| 4. Inner Steel Plate | 8. Measured Clearance |

96J30865

Fig. 29: Installing K-2 Clutch Pack

Courtesy of Mercedes-Benz of North America.

2ND ONE-WAY CLUTCH

Disassembly

Remove snap ring and one-way clutch from clutch hub. See Fig. 30. Remove inner snap ring, support disc and "O" ring. Separate inner race from roller cage and remove roller cage.

Inspection

Check all components for wear or damage and replace as necessary.

Reassembly

To reassemble, reverse disassembly procedure. Ensure rollers do not fall out of cage assembly during reassembly. Install inner race into roller cage. Using a plate approximately $2 \frac{3}{16}$ " (55 mm) square, turn roller cage while pressing down on outer race assembly. An additional person may be required to assemble. Ensure "O" ring seats correctly in groove.

AUTO TRANS DIAGNOSIS - 722 SERIES

Article Text (p. 40)

1996 Mercedes-Benz C220

Copyright © 1998 Mitchell Repair Information Company, LLC
Wednesday, January 26, 2000 12:03PM

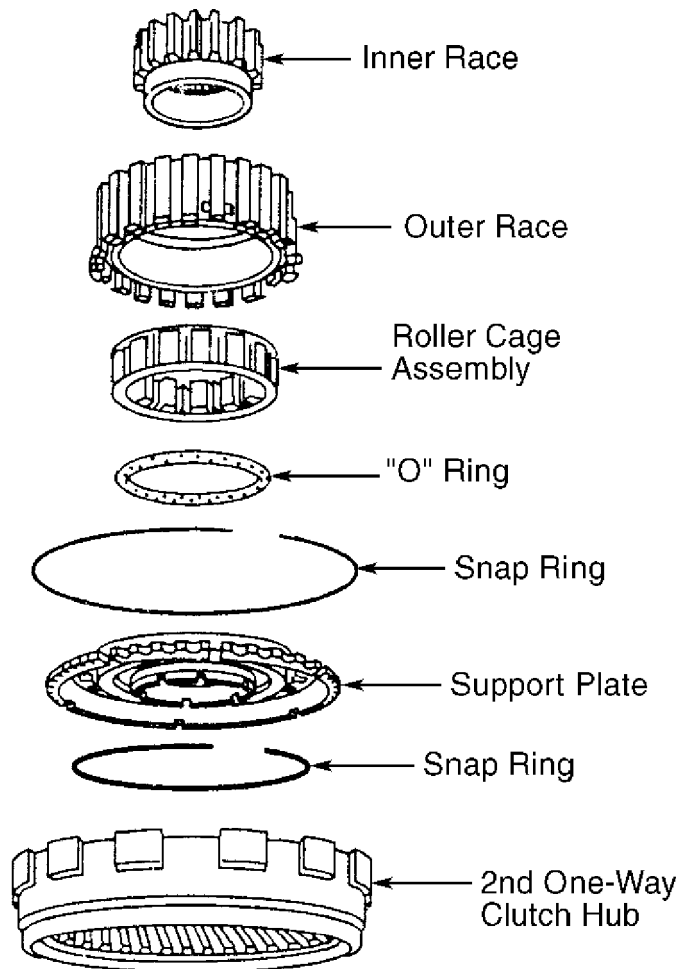

96A30866

Fig. 30: Exploded View Of 2nd One-Way Clutch
Courtesy of Mercedes-Benz of North America.

OVERDRIVE CLUTCH

Disassembly

1) Remove snap ring and clutch plates from plate carrier. See Fig. 31. Remove spring washer and install spring compressor. Compress spring plate enough to remove snap ring.

2) Remove spring compressor and spring plate. Remove pressure springs, sealing rings and piston.

Inspection

Check sealing rings for wear and replace if necessary. Lubricate sealing rings with ATF before reassembly.

Reassembly

1) Place Installation Sleeve (129589001400) on plate carrier and install inner sealing ring ensuring outer lip points downward. Install piston and remove installation sleeve. Install pressure springs.

AUTO TRANS DIAGNOSIS - 722 SERIES

Article Text (p. 41)

1996 Mercedes-Benz C220

Copyright © 1998 Mitchell Repair Information Company, LLC
Wednesday, January 26, 2000 12:03PM

2) Place installation sleeve on plate carrier and install outer seal ring on to spring plate. Install spring plate and place snap ring on spring plate. Remove installation sleeve. Install spring compressor and compress spring plate. Insert snap ring into groove securing spring plate.

3) Remove spring compressor and install clutch plates. See Fig. 32. Install snap ring. Using a feeler gauge, check clutch pack end play between top outer plate and snap ring. End play should be .059-.083" (1.5-2.1 mm). If necessary, adjust end play by changing snap ring. Snap ring thicknesses are available from .079-.138" (2.0-3.5 mm) in .020" (.5 mm) increments. If correct clearance cannot be obtained by changing snap ring, change thickness of outer clutch plate.

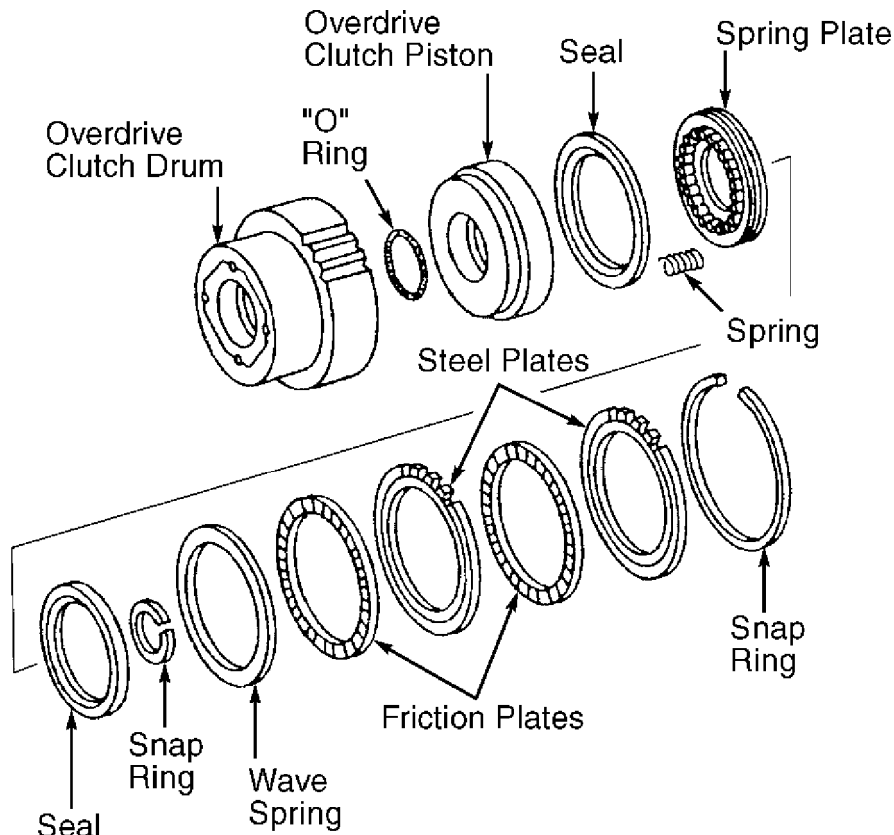

96B30867

Fig. 31: Exploded View Of Overdrive Clutch Assembly
Courtesy of Mercedes-Benz of North America.

AUTO TRANS DIAGNOSIS - 722 SERIES

Article Text (p. 42)

1996 Mercedes-Benz C220

Copyright © 1998 Mitchell Repair Information Company, LLC
Wednesday, January 26, 2000 12:03PM

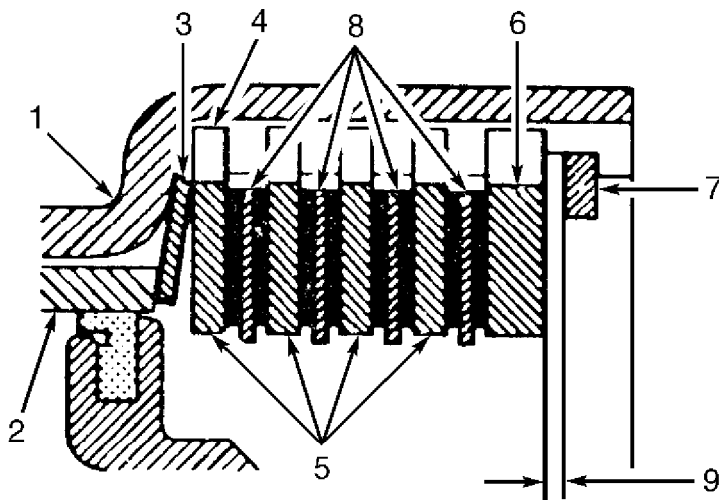

- | | | |
|-------------------|----------------------|-----------------------|
| 1. Clutch Carrier | 4. Inner Steel Plate | 7. Snap Ring |
| 2. Clutch Piston | 5. Steel Plate | 8. Friction Plate |
| 3. Wave Spring | 6. Outer Steel Plate | 9. Measured Clearance |

96C30868

Fig. 32: Installing Overdrive Clutch Plates
Courtesy of Mercedes-Benz of North America.

TRANSMISSION REASSEMBLY

NOTE: During reassembly, lubricate bearing and valve body sliding surfaces with ATF. Soak new brake bands and clutch inner plates in ATF for at least one hour prior to installation.

1) Place transmission case in holding fixture. Install guide ring and sealing ring in transmission housing. Sealing lip should face direction of brake band piston cover. Install "O" ring and radial sealing ring into selector lever shaft bores.

2) Install screw-on plug and aluminum sealing ring. Install "O" ring in support flange bore of transmission case. Install Teflon rings on clutch K-2 support flange. Install support flange and tighten bolts to specifications. See TORQUE SPECIFICATIONS.

NOTE: With brake band B-2 thrust element removed, the bore and tab on thrust element must align. With thrust element installed, one spring winding must be visible through the bore for lower cover oil pipe.

3) Install brake band B-2 thrust element with tab in upward direction. Install thrust washer on support flange so that tab engages housing. Ensure Teflon rings on support flange are still in their grooves.

4) Compress brake band B-2 by support tabs as much as possible and install. Brake band may be held in place with a snap ring. Install clutch K-2 on planetary gear set. While rotating input shaft, install planetary gear set assembly into case.

5) Place transmission in a vertical position with input shaft

AUTO TRANS DIAGNOSIS - 722 SERIES

Article Text (p. 43)

1996 Mercedes-Benz C220

Copyright © 1998 Mitchell Repair Information Company, LLC
Wednesday, January 26, 2000 12:03PM

pointing upward. Ensure planetary gear set is properly installed. Planetary gear set is properly installed when upper edge of connecting carrier is lower than supporting surface of brake B-3 outside plate. Install damping spring.

6) Install brake B-3 clutch plates and compensating (spring) washer. See Fig. 33. Place Parallel Bar (126589043100) on machined surface of transmission case. Place top of depth gauge on bar and tip of depth gauge on compensating (spring) washer. See Fig. 34. Measure and record distance.

7) Install gasket on front cover. Place parallel bar on top of brake B-3 piston. Place top of depth gauge on parallel bar and tip of depth gauge on gasket. See Fig. 35. Measure and record distance.

8) Difference between clutch pack depth measurement and piston height measurement is brake B-3 release clearance. Clearance should be .059-.079" (1.50-2.00 mm). Adjust clearance by changing thickness of brake B-3 outside plate(s).

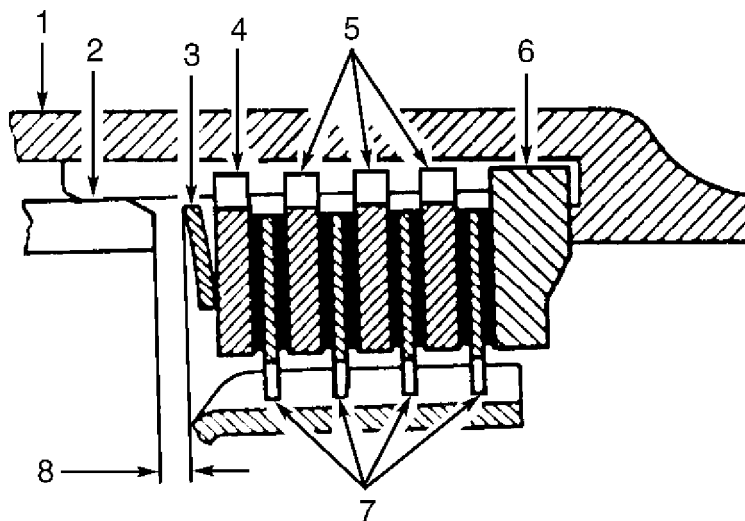

- | | |
|----------------------|-----------------------|
| 1. Clutch Carrier | 5. Steel Plate |
| 2. Clutch Piston | 6. Outer Steel Plate |
| 3. Wave Spring | 7. Friction Plate |
| 4. Inner Steel Plate | 8. Measured Clearance |

96D30869

Fig. 33: Installing Brake B-3 Clutch Pack
Courtesy of Mercedes-Benz of North America.

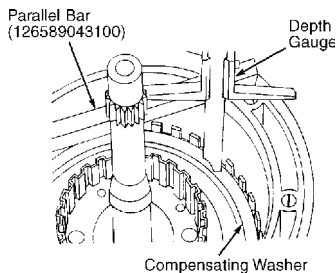

93C25009

Fig. 34: Measuring Brake B-3 Clutch Pack Depth
Courtesy of Mercedes-Benz of North America.

AUTO TRANS DIAGNOSIS - 722 SERIES

Article Text (p. 45)

1996 Mercedes-Benz C220

Copyright © 1998 Mitchell Repair Information Company, LLC
Wednesday, January 26, 2000 12:03PM

Rear Cover Installed016-.024 (.40-.60)
722.4 Series	
Rear Cover Removed024-.039 (.60-1.00)
Rear Cover Installed012-.020 (.30-.50)
AA	

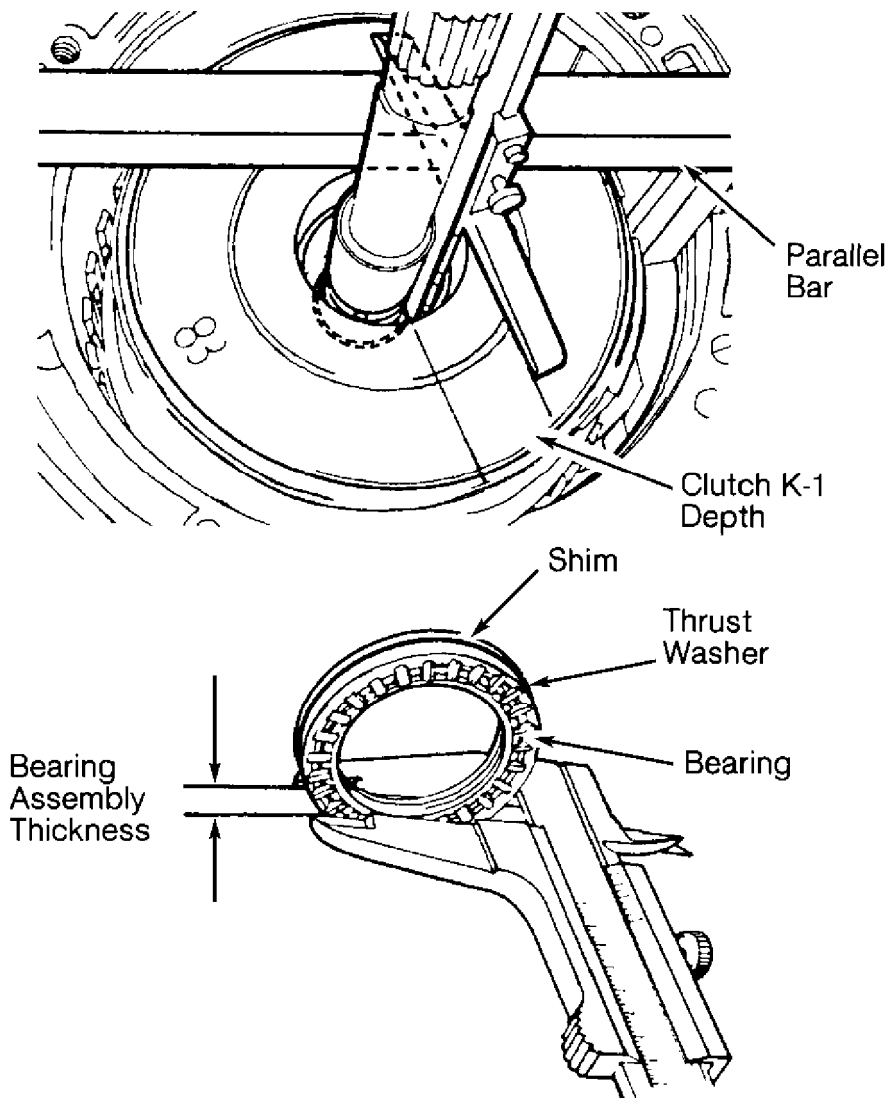

93H25012
Fig. 36: Measuring Clutch K-1 Axial Play (722.3 & 722.4 Series)
Courtesy of Mercedes-Benz of North America.

14) On 722.3 or 722.4 Series transmissions, go to step 22).
On 722.5 Series transmissions, ensure lubricating nozzle is installed and install thrust bearing. Lubricate overdrive brake piston "O" rings with ATF and press piston into transmission case. Install Teflon rings until seated into grooves. Install wave spring and overdrive brake piston snap ring.

15) Install overdrive brake clutch plates and snap ring. Using feeler gauge, measure overdrive brake clutch plate clearance between top plate and snap ring. See Fig. 37. Clearance should be .

AUTO TRANS DIAGNOSIS - 722 SERIES

Article Text (p. 46)

1996 Mercedes-Benz C220

Copyright © 1998 Mitchell Repair Information Company, LLC
Wednesday, January 26, 2000 12:03PM

020-.043" (0.5-1.1 mm). Replace snap ring to obtain proper clearance.

16) Place overdrive clutch assembly inside overdrive brake clutch plates. Install overdrive brake hub and sun gear. Install planet carrier gear with thrust bearing in place. Ensure thrust bearing does not move. Install original shims onto thrust bearing.

17) Using depth gauge, measure distance between output shaft thrust bearing race and inner thrust bearing race. See Fig. 38. Measure depth between shims and thrust bearing. See Fig. 39. Using following formula determine shim thickness for correct axial play:

$$\text{Shim Thickness} = "A" - "B" .004" (.100 \text{ mm})$$

"A" = Output shaft depth measurement.

"B" = Thrust bearing to shim measurement.

.004" (.100 mm) = Standard axial play.

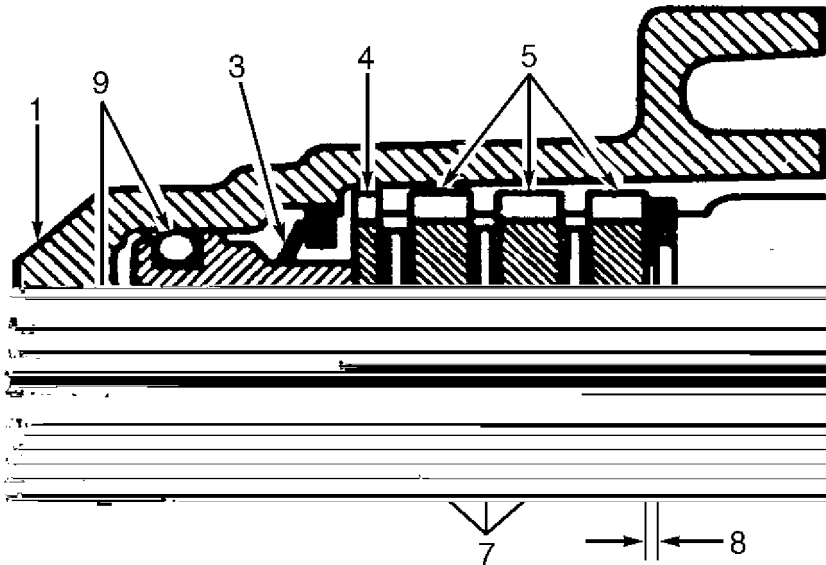

1. Clutch Carrier

2. Clutch Piston

3. Wave Spring

4. Inner Steel Plate

5. Steel Plate

6. Snap Ring

7. Friction Plate

8. Measured Clearance

9. "O" Ring

96G30870

Fig. 37: Measuring Overdrive Brake Clutch Clearance

Courtesy of Mercedes-Benz of North America.

AUTO TRANS DIAGNOSIS - 722 SERIES

Article Text (p. 47)

1996 Mercedes-Benz C220

Copyright © 1998 Mitchell Repair Information Company, LLC
Wednesday, January 26, 2000 12:03PM

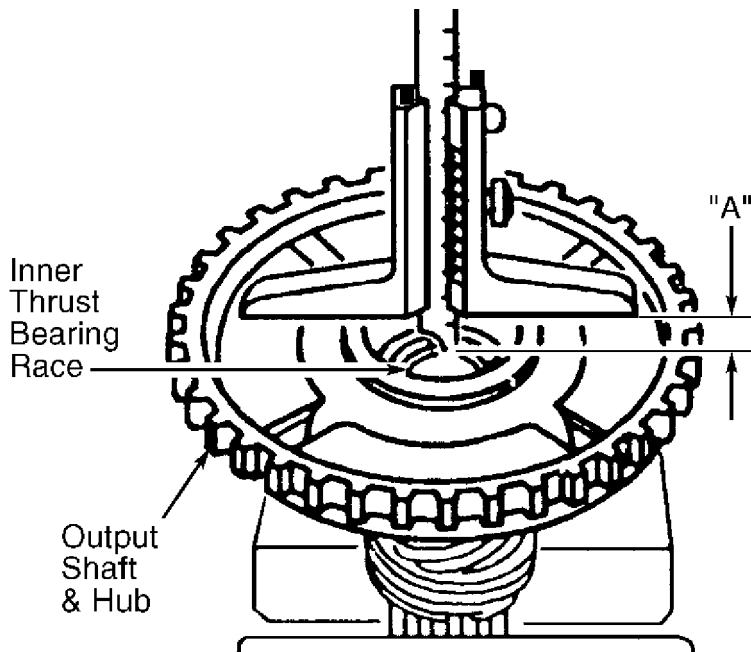

96H30871

Fig. 38: Measuring Output Shaft Inner Thrust Bearing Race Depth
Courtesy of Mercedes-Benz of North America.

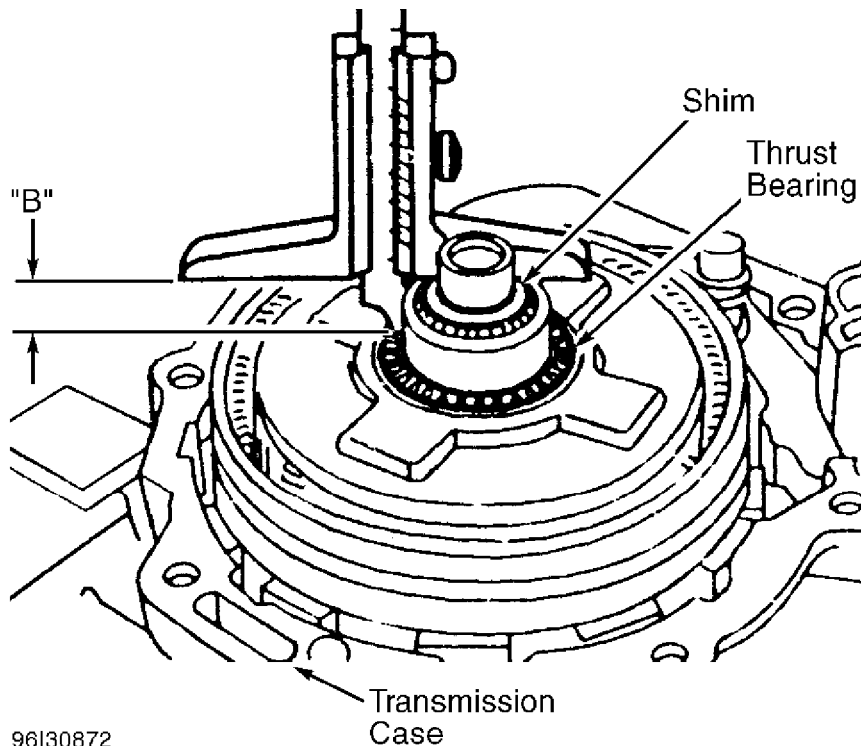

96I30872

Fig. 39: Measuring Intermediate Shaft Thrust Bearing Height
Courtesy of Mercedes-Benz of North America.

18) Remove original shims and install shim(s) required to obtain standard axial play. Install output shaft and secure with snap

AUTO TRANS DIAGNOSIS - 722 SERIES

Article Text (p. 48)

1996 Mercedes-Benz C220

Copyright © 1998 Mitchell Repair Information Company, LLC
Wednesday, January 26, 2000 12:03PM

ring. Install measuring disc and using depth gauge, measure between thrust bearing race inside rear cover and measuring disc. See Fig. 40.

19) Mount measuring disc and 3-arm flange onto intermediate shaft. Install plastic guide, parking lock pawl and spring. Engage parking lock pawl. Install flange nut and torque to 74 ft. lbs. (100 N.m). Install rear cover gasket onto transmission case. Using depth gauge, measure between gasket surface and measuring disc. See Fig. 41.

20) Use following formula to determine shim thickness for correct axial play between rear cover and output shaft:

$$\text{Shim Thickness} = "A" - "B" + .016" (.400 \text{ mm})$$

"A" = Rear cover thrust bearing depth measurement.

"B" = Output shaft height measurement.

.016" (.400 mm) = Standard axial play.

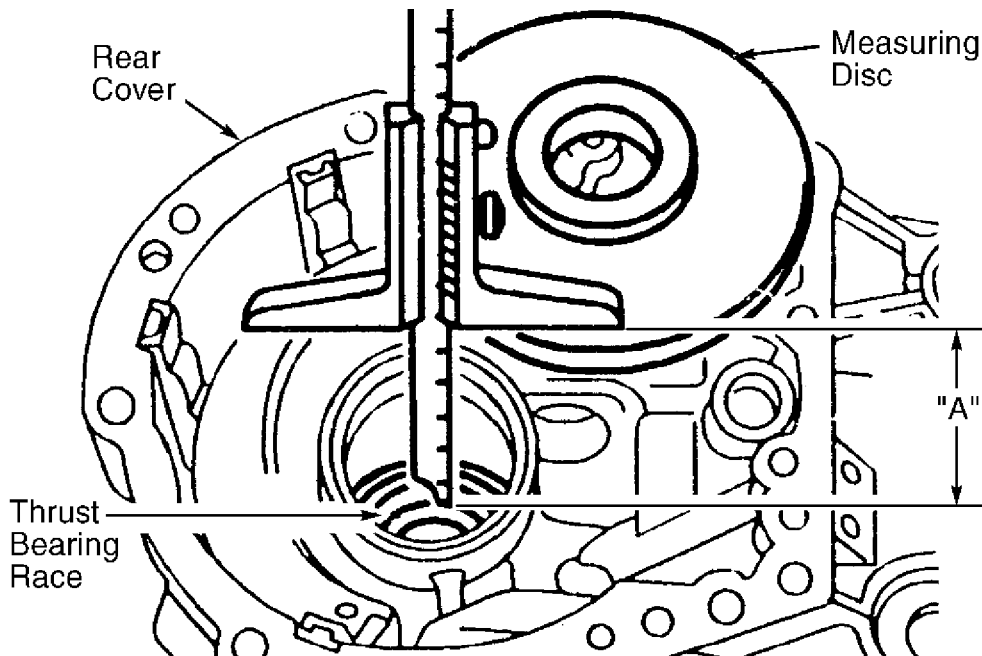

96J30873

Fig. 40: Measuring Rear Cover Inner Thrust Bearing Race Depth
Courtesy of Mercedes-Benz of North America.

AUTO TRANS DIAGNOSIS - 722 SERIES

Article Text (p. 49)

1996 Mercedes-Benz C220

Copyright © 1998 Mitchell Repair Information Company, LLC
Wednesday, January 26, 2000 12:03PM

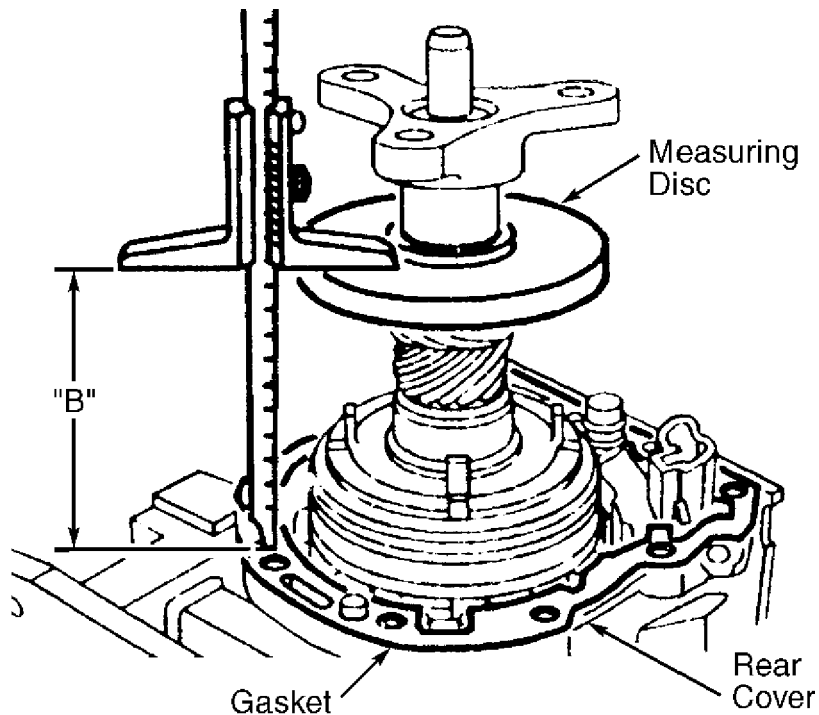

96A30874

Fig. 41: Measuring Output Shaft Height
Courtesy of Mercedes-Benz of North America.

21) Remove flange nut, 3-arm flange and measuring disc. Replace shim with shim(s) required to obtain standard axial play. Install electrical plug for solenoid valves. Install rear cover, 3-arm flange and torque all bolts to specifications. See TORQUE SPECIFICATIONS.

22) On all transmissions, coat Teflon rings on front cover with grease. Diagonal cut on rings must be held closed by grease. If necessary, remove rings and shape to a smaller diameter. Install front cover and gasket. Coat front cover bolt with non-hardening sealant and install.

23) Rotate transmission so output shaft is pointing upward. Install snap ring on groove of output shaft. Install helical gear on output shaft (722.3 Series transmissions only). Install governor axial retainer. Install "O" ring and governor. Swivel axial retainer (if equipped) toward governor so it will enter groove of governor shaft. Install governor cover and snap ring. Pull cover out so it rests on snap ring.

24) Install intermediate plate, "O" ring, and secondary pump. See Fig. 7. Ensure governor axial retainer is properly seated and install nut. See Fig. 42. Install oil pipe and bolt (if equipped).

25) Install detent plate, linkage and shaft (or bolt). Mount roller on linkage and install plastic guide over roller. On 722.3 and 722.4 Series transmissions, install shim(s) on helical gear. Mount parking lock pawl, insert spring, and attach spring to pawl. Install parking lock gear.

AUTO TRANS DIAGNOSIS - 722 SERIES

Article Text (p. 50)

1996 Mercedes-Benz C220

Copyright © 1998 Mitchell Repair Information Company, LLC
Wednesday, January 26, 2000 12:03PM

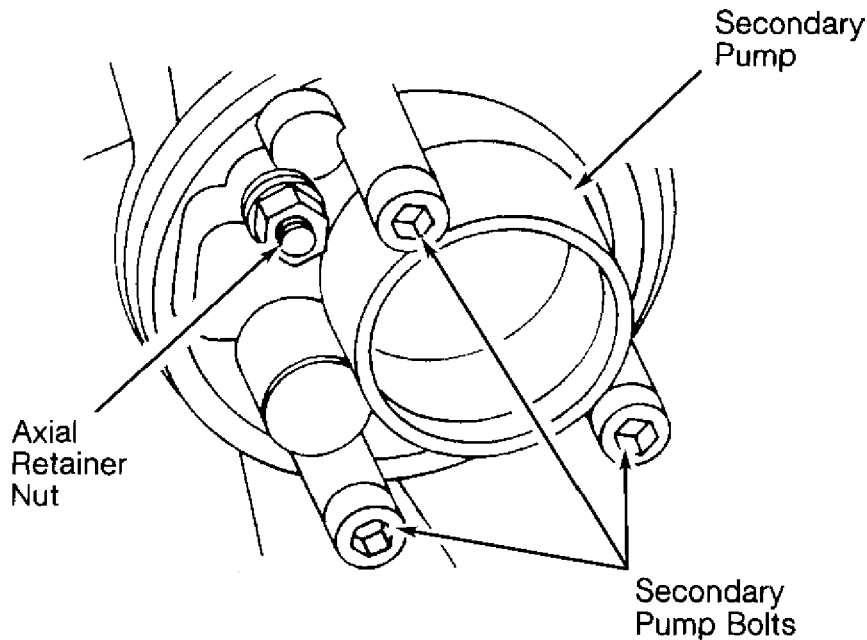

93I25013

Fig. 42: Installing Axial Retainer Nut
Courtesy of Mercedes-Benz of North America.

NOTE: On 722.3 Series transmissions, use steps 26) through 28) to adjust output shaft end play. On 722.4 Series transmissions, use steps 29) and 30) to adjust output shaft end play.

26) On 722.3 Series transmissions, install Measuring Sleeve (126589061400) over output shaft. Tighten output shaft nut to 74 ft. lbs. (100 N.m), engaging parking lock pawl to keep assembly from turning. Install rear cover gasket.

27) Place parallel bar across rear cover gasket surface. Measure from top of parallel bar to flange of measuring sleeve. See Fig. 43. Add .59" (15.0 mm) to measurement to compensate for parallel bar height and lip of measuring sleeve. Record measurement.

28) Assemble rear cover. Measure distance from rear cover sealing surface to inner race of radial bearing. Subtract this measurement from measurement made in step 27) to obtain output shaft end play. End play should be .011-.020" (.30-.50 mm). Adjust end play by adding or removing shims under parking lock pawl.

AUTO TRANS DIAGNOSIS - 722 SERIES

Article Text (p. 51)

1996 Mercedes-Benz C220

Copyright © 1998 Mitchell Repair Information Company, LLC
Wednesday, January 26, 2000 12:03PM

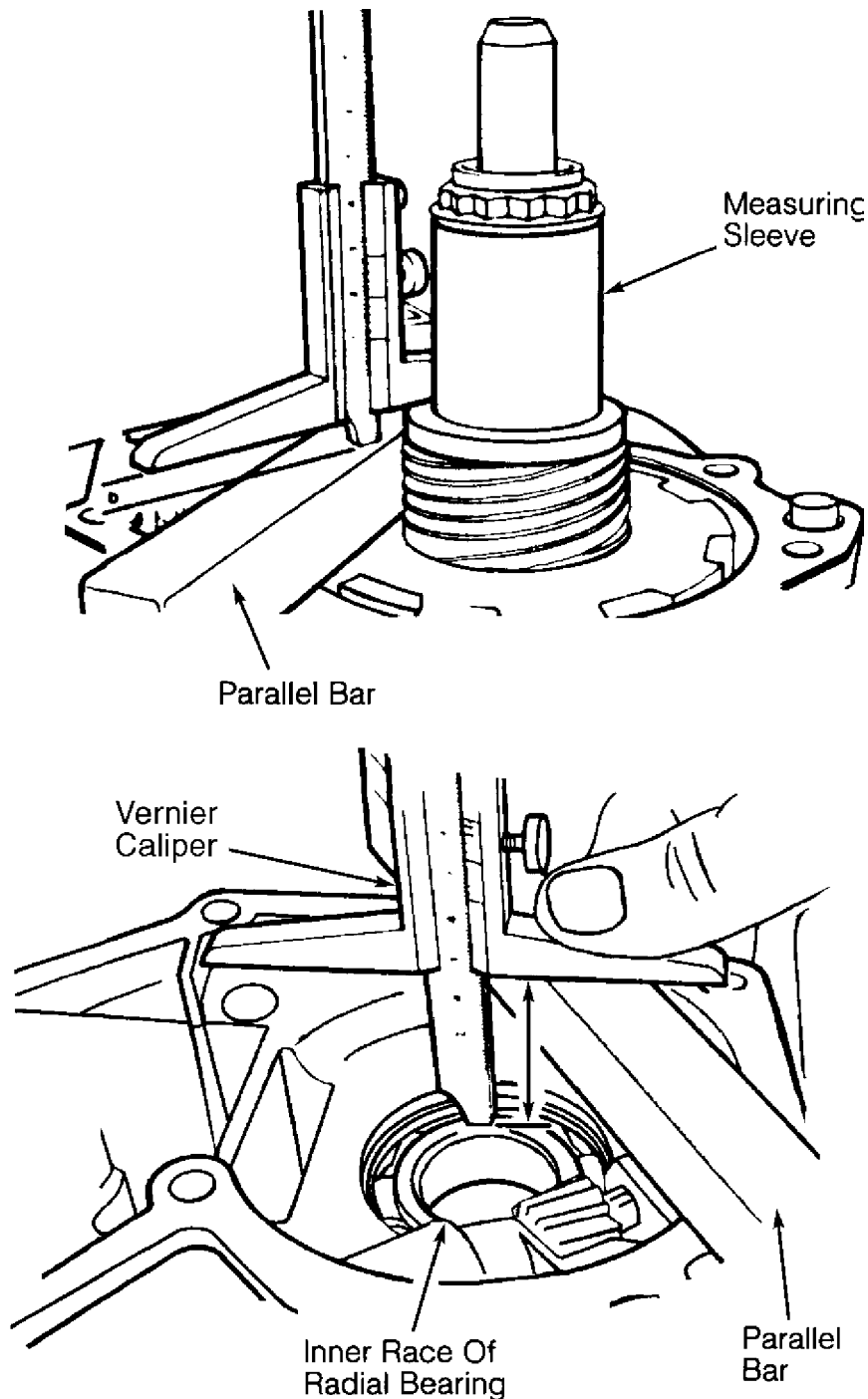

93J25014

Fig. 43: Measuring Output Shaft End Play (722.3 Series)
Courtesy of Mercedes-Benz of North America.

29) On 722.4 Series transmissions, place Measuring Disc (129589062300) on rear cover surface. See Fig. 44. Measure and record distance between measuring disc and ball bearing inner race. Install measuring disc and output shaft flange over output shaft. Tighten output shaft nut to 74 ft. lbs. (100 N.m), engaging parking lock pawl

AUTO TRANS DIAGNOSIS - 722 SERIES

Article Text (p. 52)

1996 Mercedes-Benz C220

Copyright © 1998 Mitchell Repair Information Company, LLC
Wednesday, January 26, 2000 12:03PM

to keep assembly from turning.

30) Install rear cover gasket. Measure and record distance between measuring disc and rear cover gasket. Difference between measurements is equal to output shaft end play. End play should be .008-.016" (.20-.40 mm). Adjust end play by adding or removing shims under parking lock pawl. Install helical gear on output shaft.

31) On all transmissions, install mechanical speedometer oil pipe (if equipped). Install rear cover and washer on output shaft. Install "O" ring in output flange. Install output flange and tighten output shaft nut to specification. See TORQUE SPECIFICATIONS. Using a drift, stake collar of output shaft nut into groove of output shaft.

32) Install kickdown solenoid. Install modulating pressure control valve and thrust pin. Install vacuum control unit (modulator) and retaining plate. Install starter lock-out switch, but DO NOT tighten screws at this time.

NOTE: Some models may have a modified vacuum modulator (identified by its plastic cover). If a customer complains of harsh upshifts, it is possible to reduce modulator pressure by 2.9 psi (.2 bar) by turning modulator cover counterclockwise all the way to end stop.

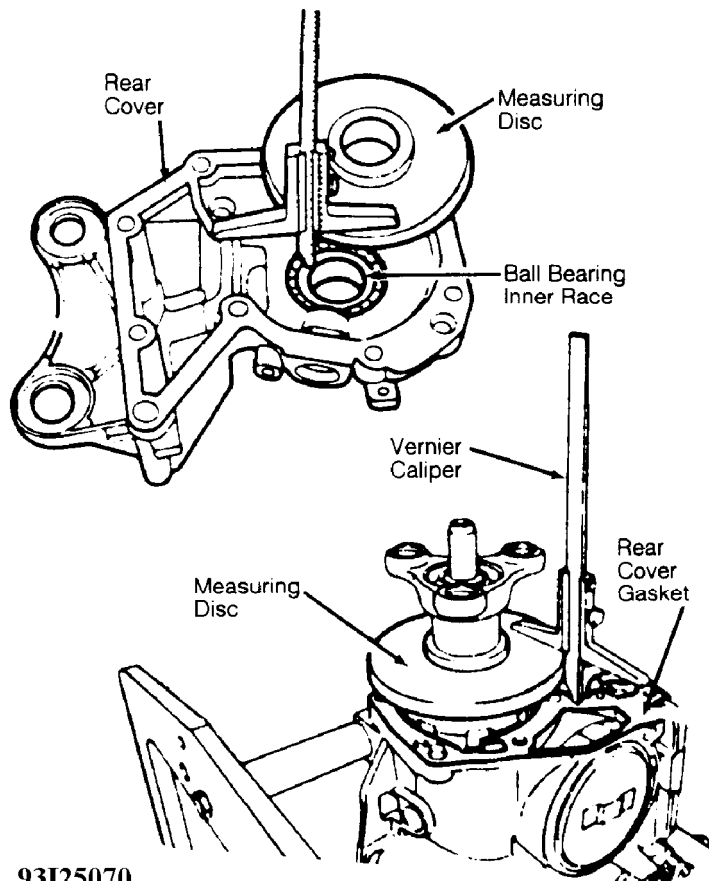

93I25070

Fig. 44: Measuring Output Shaft End Play (722.4 Series)
Courtesy of Mercedes-Benz of North America.

AUTO TRANS DIAGNOSIS - 722 SERIES

Article Text (p. 53)

1996 Mercedes-Benz C220

Copyright © 1998 Mitchell Repair Information Company, LLC
Wednesday, January 26, 2000 12:03PM

33) On 722.3 Series transmissions, install sealing ring on brake band B-1 piston, with lip pointing away from pin. Using assembly fixture, compress brake band B-1 piston, outer return spring and measuring plate. Install snap ring and remove assembly fixture. Turn measuring plate bolt by hand until resistance is felt.

34) Turn measuring plate bolt with INCH-lb. torque wrench, and count number of turns required to tighten bolt to 9 INCH lbs. (1 N.m). With 9 INCH lbs. (1 N.m) torque, brake band travel should be .07-.08" (1.8-2.0 mm). Adjust brake band clearance by adding or removing shim(s) underneath thrust pin.

NOTE: Measuring plate and screw have a 1-mm thread pitch, one turn on screw equals 1 mm of travel. For brake band pistons with removable thrust pin, use a bolt without measuring tip.

35) On 722.4 Series transmissions, install sealing ring on brake band B-1 piston, with lip pointing away from pin. Using assembly fixture, compress brake band B-1 piston, both inner and outer return springs and measuring plate. Install snap ring and remove assembly fixture. Turn measuring plate bolt by hand until resistance is felt.

36) Turn measuring plate bolt with INCH-lb. torque wrench, and count number of turns required to tighten bolt to 9 INCH lbs. (1 N.m). With 9 INCH lbs. (1 N.m) torque, brake band travel should be .07-.09" (1.8-2.4 mm) Adjust brake band clearance by adding or removing shim(s) underneath thrust pin, or install a brake band piston having a longer or shorter thrust pin.

37) Install assembly fixture and remove brake band B-1 piston and measuring plate. Install brake band B-1 piston, return springs, shim(s), thrust pin and piston cover. Install snap ring and remove assembly fixture.

38) Install thrust pin thrust element into brake band B-2 piston with large diameter toward brake band B-2. Install sealing ring and thrust pin on piston. Install piston in transmission, ensuring thrust pin engages brake band.

39) Install brake band B-2 piston cover and snap ring. Push brake band support lug in direction of brake band piston until piston rests against piston cover. See Fig. 45. Using vernier caliper, measure and record distance between support lug and brake band end.

AUTO TRANS DIAGNOSIS - 722 SERIES

Article Text (p. 54)

1996 Mercedes-Benz C220

Copyright © 1998 Mitchell Repair Information Company, LLC
Wednesday, January 26, 2000 12:03PM

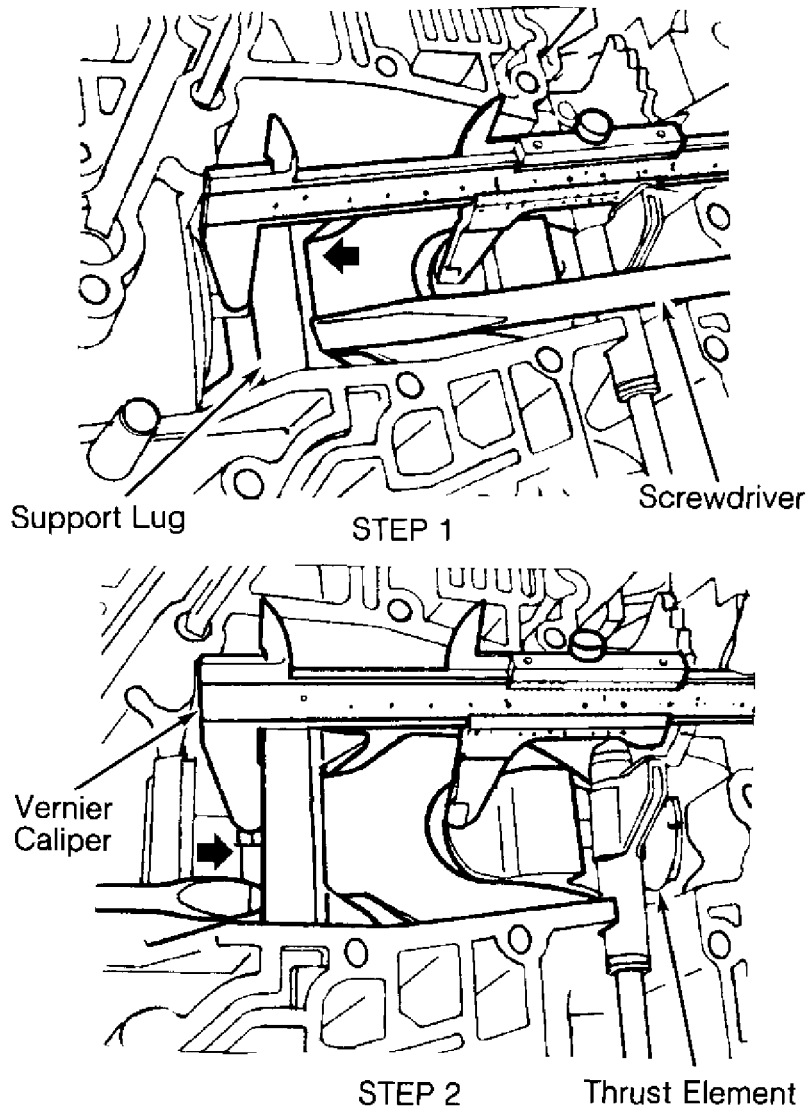

93J25071

Fig. 45: Measuring Brake Band B-2 Free Play
Courtesy of Mercedes-Benz of North America.

40) On 722.3 and 722.4 Series transmissions, push brake band support lug toward thrust element. Measure and record distance between support lug and brake band end. Brake band B-2 clearance should be .216-.220" (5.5-5.6 mm). Adjust clearance by changing thrust pin. Thrust pin is available in lengths of 1.85-1.95" (47.2-49.6 mm) in increments of .030" (.8 mm).

41) On all transmissions, insert brake band B-2 guide, one-way check valve, locating pin, temperature (throttle) restrictor, oil deflector, and filler piece (if equipped). Assemble lower cover and intermediate plate.

42) Install lower cover and intermediate plate, ensuring oil pipe is positioned in bore. Center intermediate plate by means of 2 corner screws. Install and tighten remaining screws. Install leaf spring with bracket and tighten bolt.

AUTO TRANS DIAGNOSIS - 722 SERIES

Article Text (p. 55)

1996 Mercedes-Benz C220

Copyright © 1998 Mitchell Repair Information Company, LLC
Wednesday, January 26, 2000 12:03PM

43) Install range selector lever, bolt and nut. Move range selector lever into Neutral and insert a .160" (4.0 mm) adjustment pin through range selector lever and into bore of starter lock-out switch. Tighten starter lock-out switch screws. Remove adjustment pin.

44) Install valve body, ensuring range selector valve engages detent plate. Install and tighten valve body bolts. Install oil filter and attaching bolts. Install oil pan with NEW gasket.

45) With selector lever in "N" position, check clearance between detent piston and stop on shift linkage. Adjust clearance to .016-.039" (.40-1.0 mm) by means of plastic clip. Plastic clip is available in 2 thicknesses.

46) Check "O" ring on control pressure cable and replace (if necessary). Engage control pressure cable in connecting rod. Insert limiting rod into transmission housing and insert control pressure cable. Turn cable clockwise until it locks into place. Press sleeve of control pressure cable into housing. Turn sleeve clockwise until tab engages housing.

TORQUE SPECIFICATIONS

TORQUE SPECIFICATIONS

AA

Application Ft. Lbs. (N.m)

Brake Band B-1 Thrust Element Plug 52 (70)

AUTO TRANS DIAGNOSIS - 722 SERIES

Article Text (p. 58)

1996 Mercedes-Benz C220

Copyright © 1998 Mitchell Repair Information Company, LLC
Wednesday, January 26, 2000 12:03PM

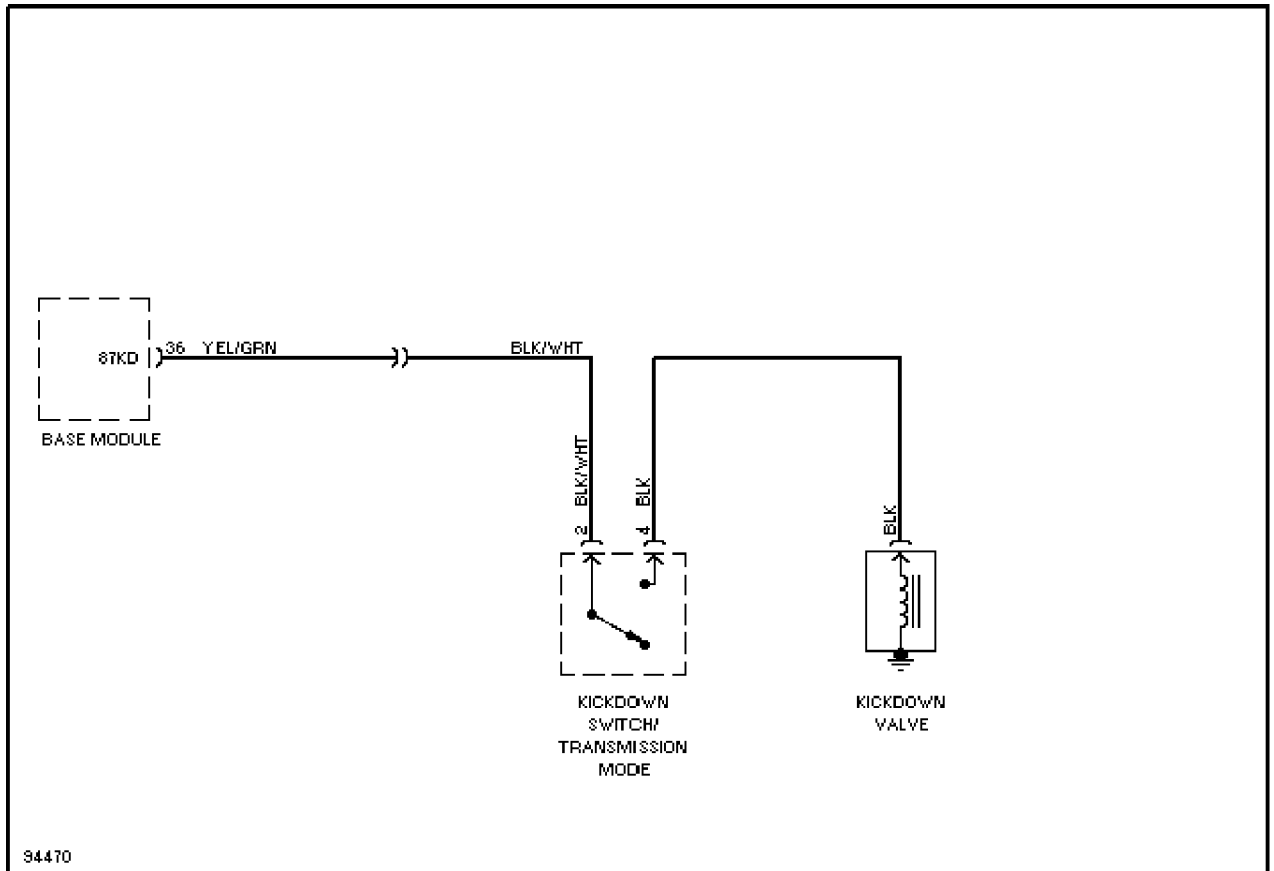

Fig. 48: Transmission Wiring Diagram (1995 S350D)

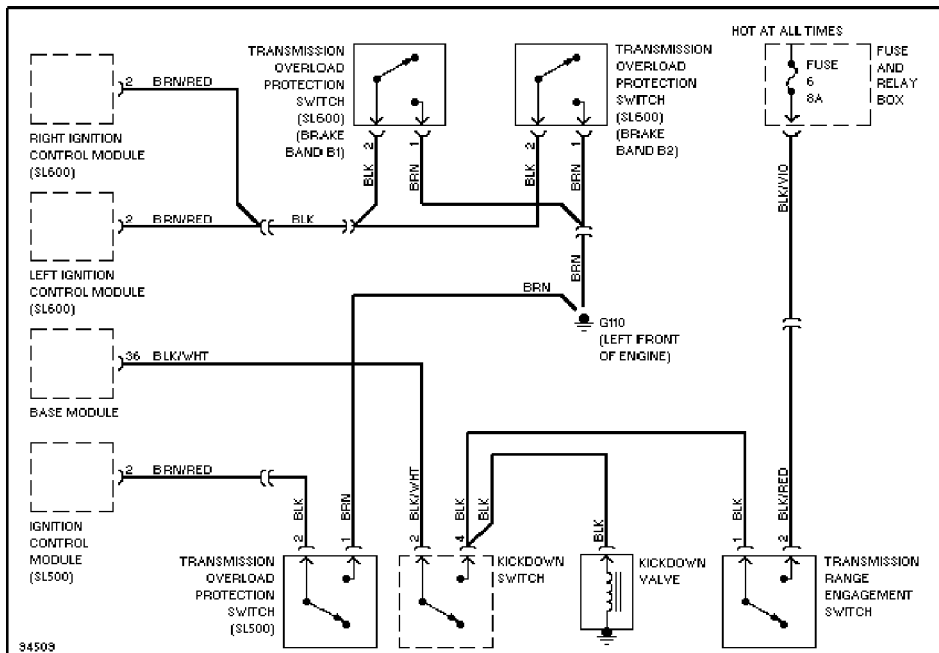

Fig. 49: Transmission Wiring Diagram (1995 SL500 & SL600)

AUTO TRANS DIAGNOSIS - 722 SERIES

Article Text (p. 59)

1996 Mercedes-Benz C220

Copyright © 1998 Mitchell Repair Information Company, LLC
Wednesday, January 26, 2000 12:03PM

END OF ARTICLE