

MODEL 124**with retrofitted anti-theft alarm system (DWA)****Shown on model 124 sedan**

i The previous lock pushbutton is no longer available. When carrying out repairs a new lock cylinder (guide) for the anti-theft alarm system must be installed.

- 1 Connection cable
 3 Lock cylinder
 S62/1 Front left door switch, ATA
 S62/1x1 Plug connection of front left door switch, ATA
 S62/2 Front right door switch, ATA
 S62/2x1 Plug connection of front right door switch, ATA

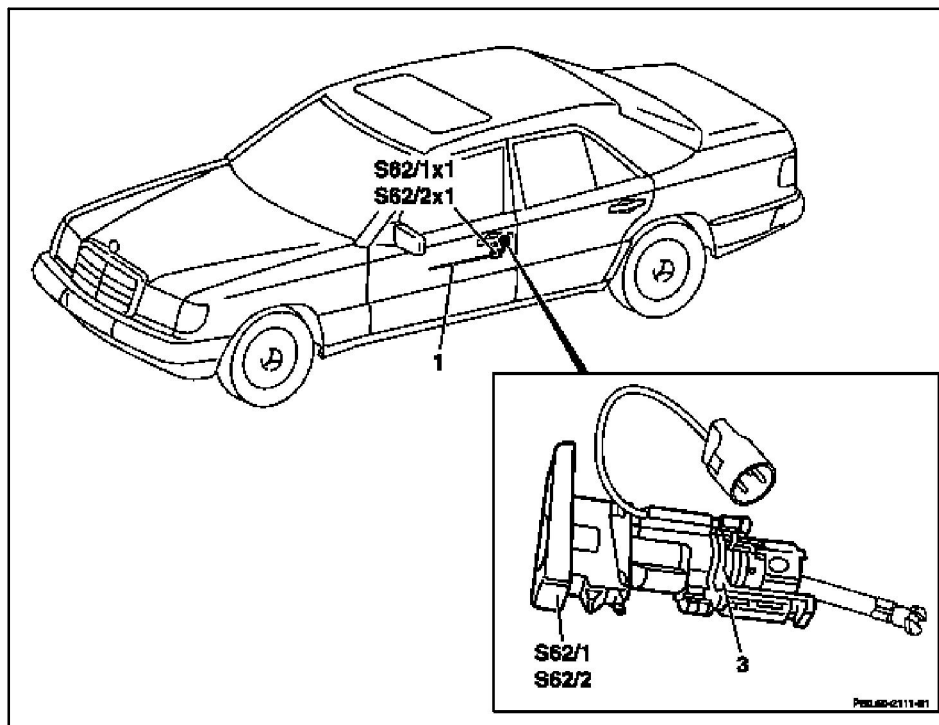

P80.50-2200-06

1	Connect quiescent current retention device		*WH58.30-Z-1005-09A
2	Disconnect ground cable of battery		
3	Remove lock cylinder of front door	i Remove only lock cylinder with faulty lock pushbutton.	
4	Remove door trim panel on inside		
X	Installation		
5	Install lock switch		
6	Install wiring harness		SM80.50-P-0002-01A
7	Perform function check	i Refer to operating instructions of anti-theft alarm system.	

Commercially available tools (see Workshop Equipment Manual)

Number	Designation	Make (e. g.)	Order number
WH58.30-Z-1005-09A	Quiescent current retention device CMP 12.2	Hans Zeheter	

Parts ordering notes

Part no.	Designation	Quantity
A201 540 98 10	Lock cylinder wiring harness	1
A201 822 10 14	Bracket	1
A124 760 01 77	Left front door lock cylinder	1
B6 654 81 36	Right front door lock cylinder	1