

01-2120 Removing and installing front cover at top

Preceding work:

Model 201: fan shroud removed (20-3400).

Cylinder head cover removed (01-0500).

Driver at camshaft removed (05-2170).

High voltage distributor removed (05-2170).

Operation no. of operation texts and work units or standard texts and flat rates

01-5700

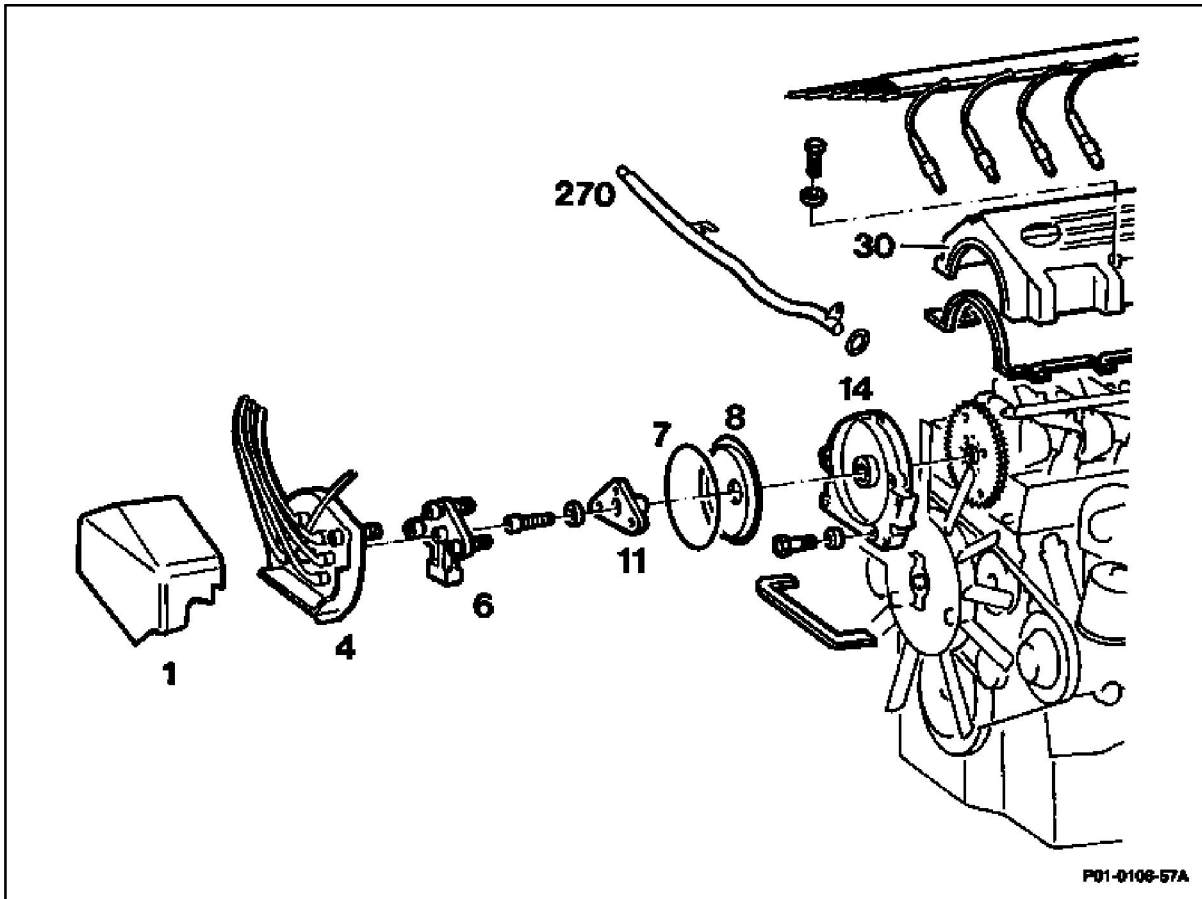

Cap of expansion tank _____ open, release pressure (step 1)
 Heating return pipe (270) _____ remove, install. Replace seal (step 2)
 Front cover at top (14) _____ remove, coat with sealant 002 989 45 20 10.
 Replace gasket (steps 3 to 6)

Front cover at top (14) _____ fit onto camshaft with insertion sleeve
 103 589 00 14 00 or 103 589 01 14 00 and tighten
 bolts to 21 Nm (steps 7 to 8).

Note

Installation _____ Examine seal in cover, replace if necessary.
 in the reverse order

Tightening torque in Nm

Front cover at top to cylinder head

21

Special tools

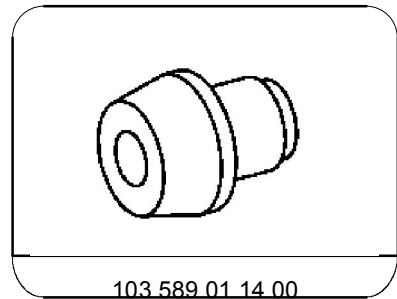
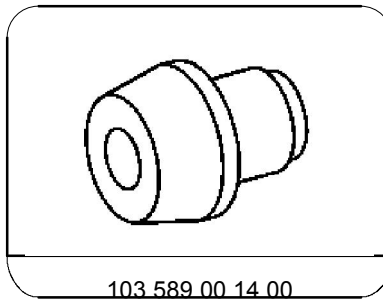
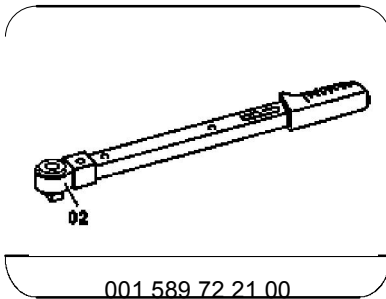

Modified gasket between front cover and timing case cover

A gasket with waver pattern is used.

This achieves improved sealing at the joint to the cylinder head.

Production breakpoint: 04/88

- 1 Open cap of expansion tank and release pressure.
- 2 Remove heating water return pipe (3).

Installation note

Replace seal.

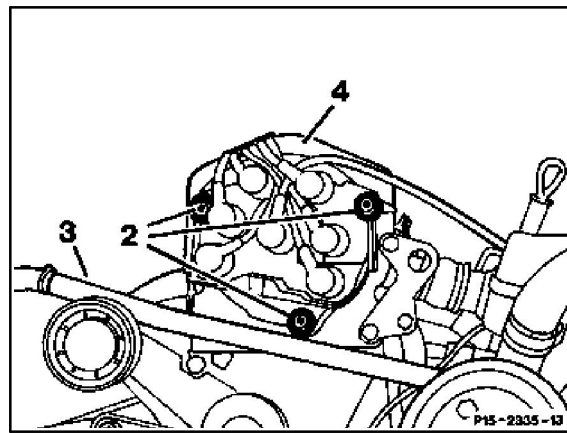

- 3 Unbolt front cover (14) and carefully knock off with a plastic-headed hammer, take off.

Note

Examine radial seal (14a) in the front cover and replace if necessary (01-2140).

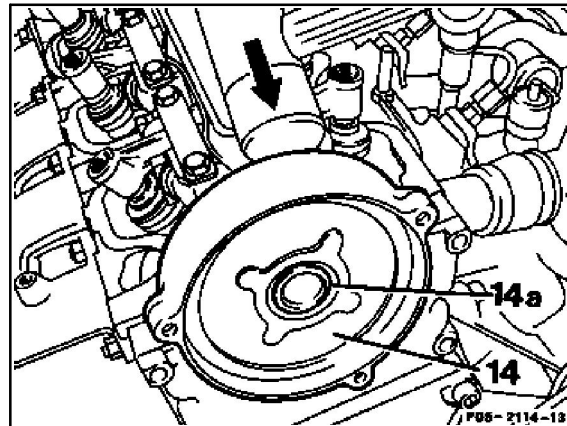

- 4 To seal, apply dots of sealant 002 989 45 20 10 (arrows) into the oil-free groove of the timing case cover on the left and right (at joint to cylinder head).

- 5 Insert new gasket (15) dry (without sealant) into the groove and push to the back.

- 6 Coat the contact surfaces of the front cover to the cylinder head with sealant 001 989 45 20 10.

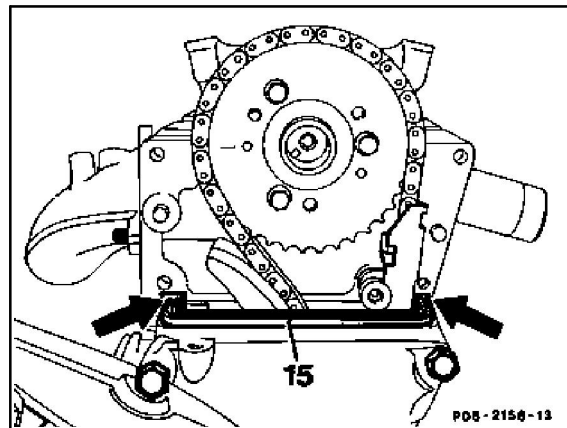

7 Fit insertion sleeve (arrow) 103 589 00 14 00 (for camshaft inner \varnothing 21.6 mm), or 103 589 01 14 (\varnothing 20 mm) onto the camshaft. Coat the sealing lip of the radial seal (14a) with engine oil. Fit on front cover (14).

Note

The front cover is centered with two dowel pins.

8 Tighten the two bottom bolts first, tightening torque 21 Nm.

Installation is performed in reverse order.

9 Top up coolant, if necessary.

